

TRIUMPH

2011 Daytona 675 (VIN 381275>) and Daytona 675 R Motorcycle Race Kit Manual



FOR CLOSED-CIRCUIT USE ONLY

Table of Contents

Introduction	3
General Information	4
Engine Parts	6
Gaskets	
Side Cover Gasket Kit	6
Cylinder Head Gasket	7
Camshafts and Valves	
Camshaft, Valve Spring & Camshaft Sprocket Kits	9
Manually Adjustable Camshaft Drive Chain Tensioner	11
Inlet & Exhaust Valve Kit	13
Bearings	
Conrod Bearing Shell	14
Main Bearing Shell	15
Oil Pump	
Oil Pump Gearing Kit	16
Induction and Exhaust	
Air Funnel Kit	18
Secondary Air Injection (SAI) Blanking Kit	20
Exhaust System, Race (Arrow)	22
Air Filter Kit	26
Manual Idle Speed Adjuster Kit	27
Transmission	
Slipper Clutch Kit	28
Slipper Clutch Tool	28
Detent Wheel Kit	29
Cooling	
Silicon Hose Kit	33
Electrical Parts	34
Race Alternator Kit	34
Programmable Race ECU	36
Fault Code Table	37
Triumph Race Calibration Software (TRACS)	38
TRACS Management Kit (Programmable Race ECU and Race Calibration Software Bundle)	39
Race Harness Kit	40
Quickshifter	42
Chassis Parts	44
Quickshifter, Race	44
Rearsets, Race, Reverse Shift (Arrow)	45
Rearsets, Race, Standard Shift (Arrow)	61

Introduction

2011 Triumph Daytona 675 and Daytona 675R

New for 2011 is the Daytona 675R, a highly specified version of the award-winning Daytona 675 fitted with race-specification suspension and brake components as standard.

To create the definitive version of the Daytona 675, Triumph turned to Swedish suspension specialists Öhlins. Together the companies specified Öhlins' 43mm NIX30 forks and TTX36 rear monoshock units normally reserved for racetrack use and very close relatives of the items used on the championship winning MotoGP and world superbike machines.

The iconic gold anodised forks feature 30mm cartridge internals, offering full compression and rebound damping and preload adjustment. At the rear, the TTX36 shock is smaller and lighter than previous Öhlins shocks and features a clever twin tube design for improved rider feedback. This twin tube technology creates positive pressure build up on both the compression and rebound stroke, guaranteeing a well-balanced action. As one would expect from such a quality unit, the TTX36 unit features a wide range of adjustment for preload, compression and rebound damping, the latter two made through separate adjusters on the top of the unit. As further evidence of the bike's track capability, both front and rear suspension units come equipped to accept the sensors required for running datalogging equipment.

Stopping the Daytona 675 are new Brembo monoblock calipers gripping 308mm discs and fitted with race arrangement braided brake lines and a bespoke 18mm Brembo radial master cylinder. The feedback and stopping power offered by this rigid four-piston set-up provides the kind of outstanding stopping power one would expect from a top-of-the-range sports machine.

A full range of race parts are available to further develop the Daytona 675 and Daytona 675R under FIM supersport regulations. These include the Triumph Race Calibration Software (TRACS), which allows adjustment of many parameters within the race kit ECU, racing harness, camshafts, air funnel kit and a titanium full race exhaust system developed in conjunction with Arrow Special Parts.

General Information

Please note:

- The Race Kit parts detailed in this publication are made in accordance with FIM technical regulations and are NOT street legal.
- The Race Kit parts covered in this publication are intended for racing purposes only and any Triumph motorcycle fitted with such kits MUST NOT be used on public roads.
- The Race Kit parts detailed in this publication may only be used on a closed-circuit in the hands of experienced riders.
- Before fitting any Race Kit parts, customers should check the technical regulations of their race class to ensure conformity.
- The information provided in this publication should always be used together with the official Triumph Daytona 675 service manual.
- Completely read all the instructions before commencing the installation and set up of the Race Kit in order to become thoroughly familiar with the kit's features and the installation process.
- When removing components which incorporate a gasket ALWAYS ensure a new gasket is fitted on re-assembly. The standard engine side cover gaskets can be replaced with re-usable items as supplied in the Side Cover Gasket Kit A9618097 (see page 6).
- The Race Kit parts detailed in this publication are not covered by any warranty.
- Prices and specifications are subject to change without notice.
- The information contained in this publication is accurate at the time of final approval, however, Triumph Motorcycles reserves the right to amend the information at any time without notice.
- Whilst every effort is made to include the latest information in the service manual, this is not always possible. The latest information and technical changes are provided to authorised Triumph dealers via Technical News. It is recommended you contact an authorised Triumph dealer to request this information.

Warnings, Cautions and Notes.

Throughout this publication particularly important information is presented in the following form:

 Warning
This warning symbol identifies special instructions or procedures, which if not correctly followed could result in personal injury, or loss of life.

 Caution
This caution symbol identifies special instructions or procedures, which if not strictly observed, could result in damage to, or destruction of, equipment.

Note:

- **This note symbol indicates points of particular interest for more efficient and convenient operation.**

 **Warning**

These accessory kits are for racing only. They are for use solely during closed-course racing. A motorcycle fitted with these kits must not be used on public roads. It is illegal to use a motorcycle fitted with these kits on public roads. A motorcycle fitted with these kits does not comply with local laws and regulations. If you use a motorcycle fitted with these kits on public roads, you may be prosecuted.

 **Warning**

These accessory kits are designed for use on Triumph Daytona 675 motorcycles only and should not be fitted to any other Triumph model or to any other manufacturer's motorcycle. Fitting these accessory kits to any other Triumph model, or to any other manufacturer's motorcycle, will affect the performance, stability and handling of the motorcycle. This may affect the riders ability to control the motorcycle and could cause an accident.

 **Warning**

Always have Triumph approved parts, accessories and conversions fitted by a trained technician of an authorised Triumph dealer. The fitment of parts, accessories and conversions by a technician who is not of an authorised Triumph dealer may affect the handling, stability or other aspects of the motorcycles operation which may result in loss of motorcycle control and an accident.

 **Warning**

Throughout this operation, ensure that the motorcycle is stabilised and adequately supported on a paddock stand to prevent risk of injury from the motorcycle falling.

 **Warning**

A torque wrench of known accurate calibration must be used when fitting this accessory kit. Failure to tighten any of the fasteners to the correct torque specification may affect motorcycle performance, handling and stability. This may result in loss of motorcycle control and an accident.

 **Warning**

If the engine has recently been running, the exhaust system will be hot. Before working on or near the exhaust system, allow sufficient time for the system to cool, as touching any part of a hot exhaust could cause burn injuries.

 **Caution**

The use of some of these kits will require changes to the fuelling and ignition settings. To alter these settings, a Triumph Programmable Race ECU combined with Triumph TRACS Race Calibration Software will be required. Failure to correct the fuelling and ignition settings will result in poor engine performance and could result in engine damage.

Engine Parts

Side Cover Gasket Kit

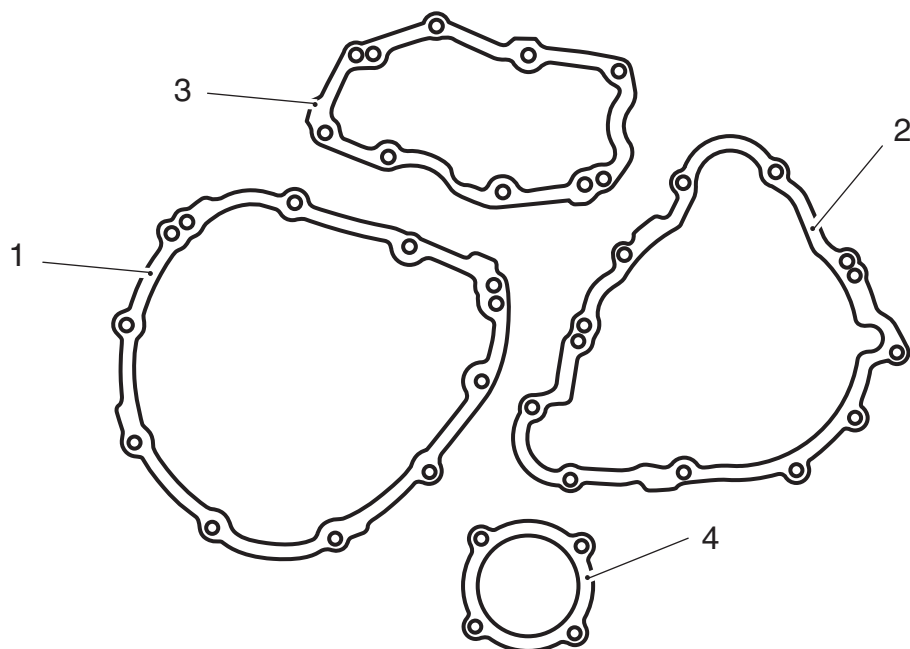

Parts Supplied - A9618097

Item	Description	Qty
1	Gasket, clutch cover, race	1
2	Gasket, alternator cover, race	1
3	Gasket, crank cover, race	1
4	Gasket, balancer cover, race	1

Note:

- **The gaskets contained in the kit are a direct replacement for the standard parts, but they have been designed to be reusable.**
- **Thoroughly clean all mating faces before fitting new gaskets.**

Cylinder Head Gasket

Caution

The use of the following Race Kit cylinder head gaskets will require changes to the fuelling and ignition settings. To alter these settings, a Triumph Programmable Race ECU combined with Triumph TRACS Race Calibration Software will be required. Failure to correct the fuelling and ignition settings will result in poor engine performance and could result in engine damage.

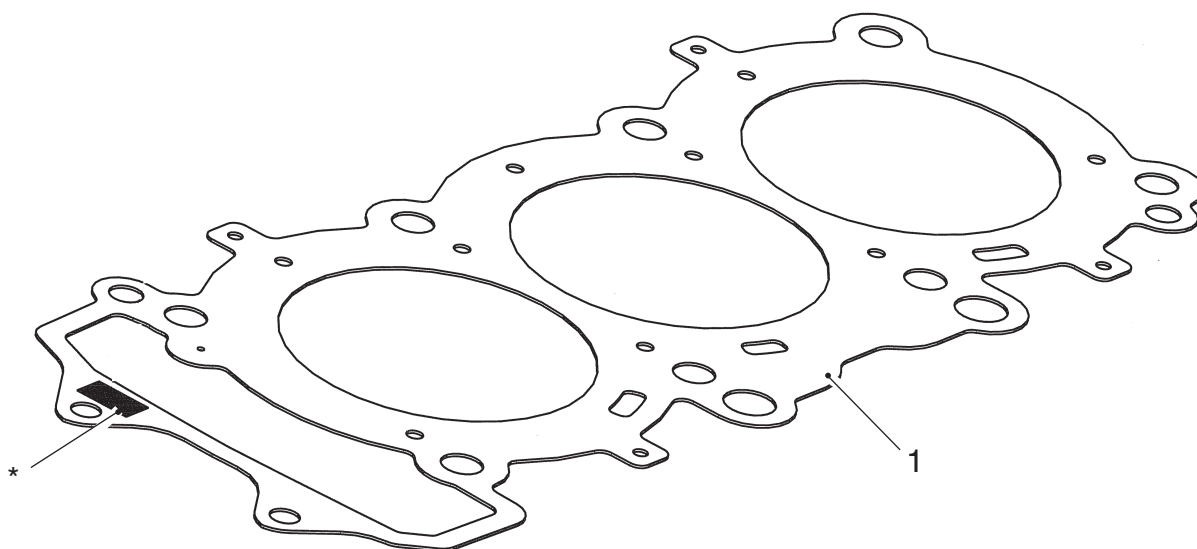

* Thickness 'T' marking location

Parts Supplied

A9618112 (0.65 mm), A9618113 (0.60 mm), A9618114 (0.55 mm) or A9618115 (0.50 mm)

Item	Description	Qty
1	Cylinder head gasket (t = 0.65 mm)	1
1	Cylinder head gasket (t = 0.60 mm)	1
1	Cylinder head gasket (t = 0.55 mm)	1
1	Cylinder head gasket (t = 0.50 mm)	1

- The thickness of the standard cylinder head gasket is 0.7 mm. The Race Kit gaskets are available in 0.60 mm, 0.65 mm, 0.55 mm and 0.50 mm thicknesses. The thickness (t) of the gasket is clearly marked on the gasket in the position (*) shown above.

Note:

- Due to variation in production tolerances, the Race Kit cylinder head gaskets may not be suitable for all engines. Use the appropriate gasket to adjust the squish height (the squish height is the gap between the flat portion of the piston and the cylinder head). Always ensure that the chosen gasket provides a minimum squish height of 0.65 mm.



Warning

Running the engine at less than the minimum recommended squish height can lead to the pistons contacting the cylinder head, causing major engine damage. This could cause loss of motorcycle control and an accident.

1. Remove the existing cylinder head gasket in line with the procedures detailed in the Daytona 675 service manual.
2. Position a piece of solder (with a diameter approximately 1.3 mm) on the four squish surfaces of each piston. Position the solder in line with the corresponding squish surfaces on the cylinder head and hold in place with a small amount of grease.
3. Refit the cylinder head with the head gasket.
4. Slowly turn the engine over, by hand, to compress the solder to the same height as the squish clearance.

5. Remove the cylinder head and head gasket.
6. Measure the compressed thickness of the solder. The squish clearance must be a minimum of 0.65 mm.
7. If the thickness of the solder is less than 0.65 mm repeat steps 2 to 6 with a thicker head gasket until the squish clearance is at an acceptable level.

Note:

- **In some cases, it may be necessary to use a standard cylinder head gasket to achieve the correct squish clearance.**
8. Fit the chosen cylinder head gasket following the procedures detailed in the Daytona 675 service manual.

Camshaft, Valve Spring & Camshaft Sprocket Kits

Warning

The Race Kit camshaft, valve Spring and camshaft sprockets must be fitted as a complete set. If they are not fitted as a complete set a failure may result which could cause loss of motorcycle control and an accident.

Caution

The use of The Race Kit camshaft, valve Spring and camshaft sprockets detailed below will require changes to the fuelling and ignition settings. To alter these settings, a Triumph Programmable Race ECU combined with Triumph TRACS Race Calibration Software will be required. Failure to correct the fuelling and ignition settings will result in poor engine performance and could result in engine damage.

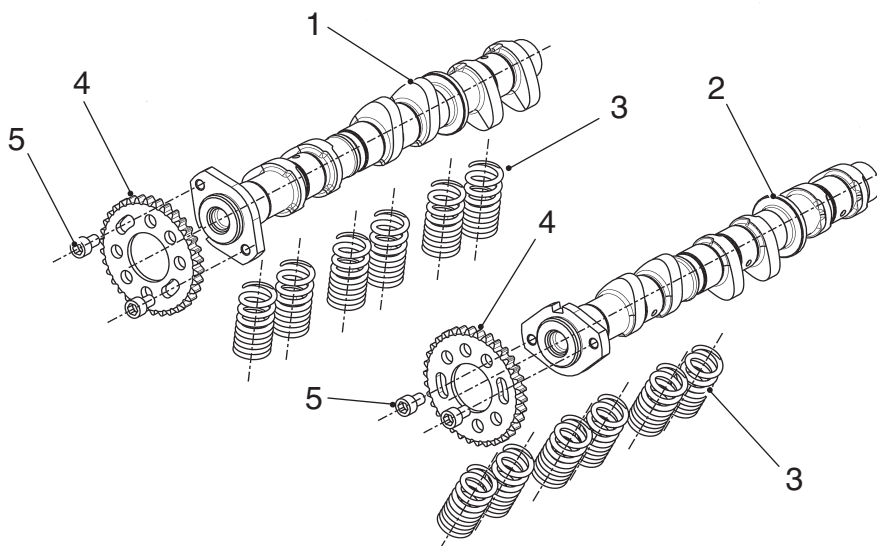

Parts Supplied

Camshaft, Inlet - A9618055

Item	Description	Qty
1	Camshaft, inlet, race	1

Camshaft, Exhaust - A9618056

Item	Description	Qty
2	Camshaft, exhaust, race	1

Valve Spring Kit - A9618086

Item	Description	Qty
3	Valve spring, 14.4 id, race	12

Camshaft Sprocket Kit - A9612122

Item	Description	Qty
4	Sprocket, camshaft, inlet, 34T	2
5	Socket head cap screw, encapsulated, M6 x 10	4

Note:

- **The standard inlet cam is 9.25 mm max lift and 258.50° duration. The Race Kit inlet cam is 9.25 mm max lift and 268.74° duration.**
- **The standard exhaust cam is 8.5 mm max lift and 246° duration. The Race Kit exhaust cam is 8.5 mm max lift and 262.21° duration.**
- **The Race Kit valve spring must be used in conjunction with the standard spring platforms and retainers. The fitted length of the race springs is the same as the standard spring.**

1. The Race Kit valve springs should be assembled in the same manner as the standard valve springs. Follow the procedure detailed in section 3 of the Daytona 675 service manual. Ensure the springs are installed with the close wound, colour coded end of the springs facing downwards, towards the piston.
2. The Race Kit camshafts should be assembled in the same manner as the standard camshafts. Follow the procedure detailed in section 3 of the Daytona 675 service manual.
3. The Race Kit cam sprockets should be mounted and secured to the camshafts using the slotted holes in the sprocket. The slotted holes allow adjustment of the valve timing. The circular holes in the sprockets are for Triumph service tool T3880102 and should not be used to mount the sprockets to the camshafts.
4. The camshafts should be timed using cam degreasing equipment which typically consists of a degree wheel, pointer, dial indicator and piston stop. Optimum cam timing will depend on the exact specification of the engine, but a recommended starting point is 106° IMOP (Inlet Maximum Opening Point) and 106.5° EMOP (Exhaust Maximum Opening Point).
5. Always check the inlet and exhaust piston to valve clearance for the timing selected to use, before running the engine. You must ensure both clearances are adequate. As a guide, the standard nominal piston to valve clearance is 1.3 mm inlet & 1.5 mm exhaust.
6. When the desired timing has been set the new socket retaining screws provided should be tightened to **15 Nm**. Note, if the screws are released for any reason, apply ThreeBond 1305 to the threads before re-tightening.

Note:

- **No timing marks are included on the race sprockets. Race engines will typically have different depths skimmed off the cylinder head and, therefore require specific individual timing.**

Manually Adjustable Camshaft Drive Chain Tensioner

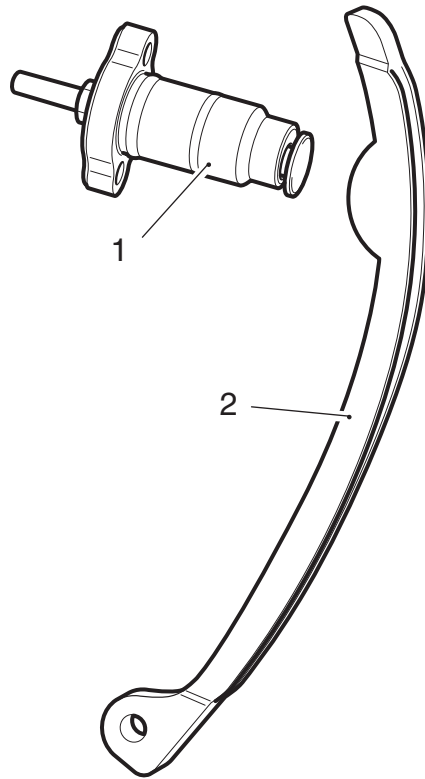

Parts supplied - A9618108

Item	Description	Qty
1	Manual camshaft drive chain tensioner assembly	1
2	Camshaft drive chain tensioner blade	1

- Remove the standard tensioner following the procedure detailed in the Daytona 675 service manual. Discard the gasket, retain the fixings for reuse.
- Remove the camshafts following the procedure detailed in the Daytona 675 service manual.
- Remove the pin locating the tensioner blade to the crankcase, retain the pin for reuse. Remove the tensioner blade from the top of the camshaft drive chain chest.
- Lower the new tensioner blade provided into the camshaft drive chain chest, from the top. Locate in position with the original pin.
- Refit the camshafts following the procedure detailed in the Daytona 675 service manual.
- Thoroughly clean the tensioner mounting surface on the cylinder head.

Caution

Do not start the motorcycle engine with the tensioner removed. If the motorcycle engine is started with the tensioner removed it could result in engine damage.

- Do not start the motorcycle engine with the tensioner removed.**

- Remove the camshafts following the procedure detailed in the Daytona 675 service manual.

7. Back off the plunger locknut on the new tensioner assembly before installation.

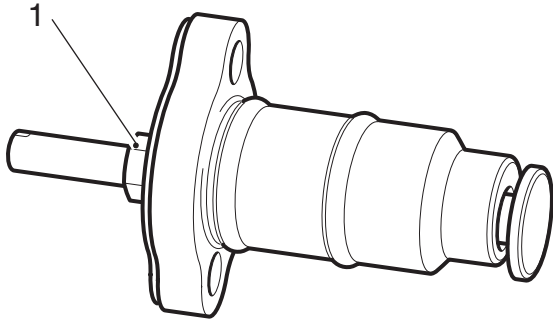

1. Plunger locknut

8. Lightly coat the two large O-rings with oil, and fit a new gasket.
9. Install the new tensioner assembly and secure with the original fixings.
10. Tighten the tensioner fixings to a torque value of **9 Nm**.
11. Finger tighten the plunger on the new tensioner while turning the crankshaft by hand. At certain points during engine rotation you will feel the plunger tighten as it takes up the slack in the camshaft drive chain. **DO NOT** force the plunger, continue steady finger tightening only to take up the slack in the chain as you rotate the crankshaft.

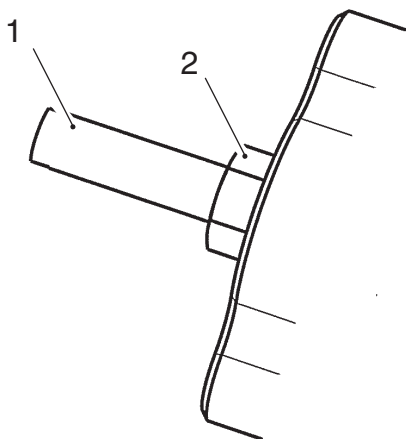

- 1. Plunger**
- 2. Plunger locknut**

12. When the slack in the camshaft drive chain has been completely taken up, back off the plunger by 1/4 turn.
13. While holding the plunger in position, tighten the plunger locknut to a torque value of **9 Nm**. Ensure the plunger is not allowed to turn while tightening the locknut.
14. Re-check the chain tension.
15. Fit a new gasket to the right hand crank cover.
16. Noting the position of the bolt fitted with the copper washer, refit the crank cover, tightening the fixings to **9 Nm**.

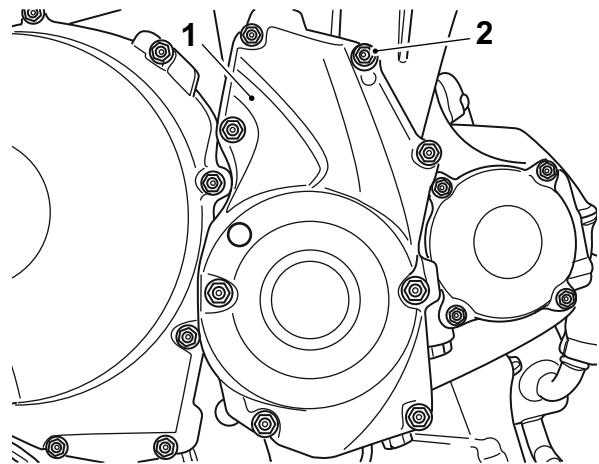

- 1. Right hand crank cover**
- 2. Copper washer position**

17. Following the procedure detailed in the Daytona 675 service manual, check the valve clearances and adjust as necessary.
18. Refit the camshaft cover, as described in the Daytona 675 service manual.

Inlet & Exhaust Valve Kit

Caution

The use of the following Race Kit inlet & exhaust valves will require changes to the fuelling and ignition settings. To alter these settings, a Triumph Programmable Race ECU combined with Triumph TRACS Race Calibration Software will be required. Failure to correct the fuelling and ignition settings will result in poor engine performance and could result in engine damage.

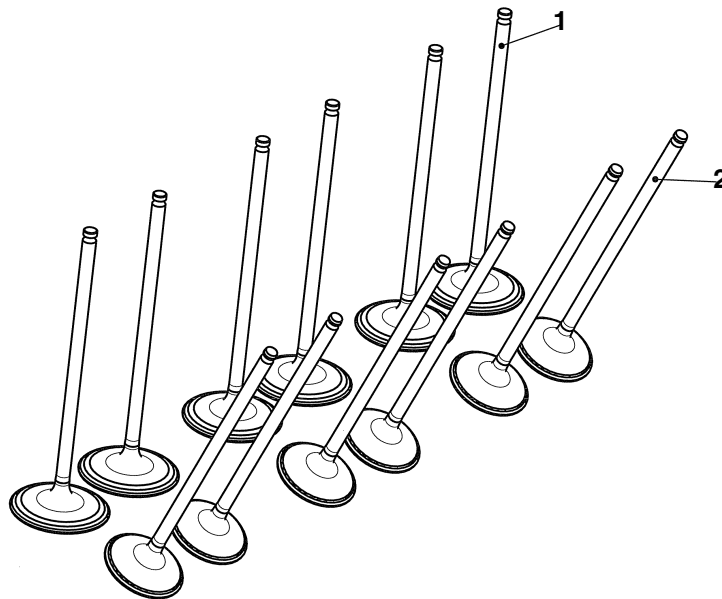

Parts Supplied - A9618061

Item	Description	Qty
1	Inlet valve, 29.65 dia	6
2	Exhaust valve, 24.85 dia	6

- **The valves supplied in the Race Kit are used to increase compression ratio, by having a flat face on the combustion chamber side. They are made from the same material and have the same mass as the standard valves.**

1. Remove the existing inlet and exhaust valves following the procedure detailed in section 3 of the Daytona 675 service manual.
2. The valve seat widths on the Race Kit valves are narrower than the standard valves, therefore the bottom angle (140° inlet / 160° exhaust) of the cylinder head valve seats must be modified to ensure the seat on the head matches the seat on the valve.
3. Check the head seat and valve seat are matched correctly by applying a small amount of engineer's blue to the valve seat, assembling the valve to the cylinder head, and rotating the valve through 360°.
4. When the correct match of head seat and valve seat have been confirmed assemble the race inlet and exhaust valves, following the procedure detailed in section 3 of the Daytona 675 service manual.

Conrod Bearing Shell

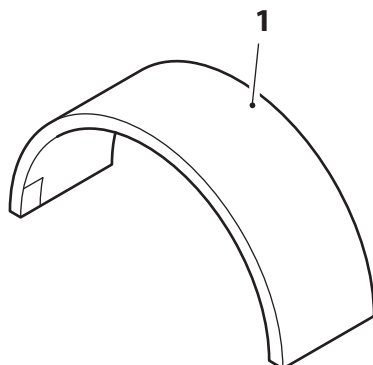

Parts Supplied - A1110411

Item	Description	Thickness	Colour	Qty
1	Conrod bearing shell, race	1.476 mm to <1.482 mm	White	1

Parts Supplied - A1110412

Item	Description	Thickness	Colour	Qty
1	Conrod bearing shell, race	1.482 mm to <1.488 mm	Red	1

Warning

Connecting rod bolts **MUST** only be used once. If the bolts are removed or undone for any reason, new bolts **MUST** always be used. Re-using bolts can cause connecting rods and their caps to detach from the crankshaft causing severe engine damage, loss of motorcycle control and an accident.

- **The Race Kit conrod bearing shells are produced in a higher grade of alloy than the standard parts. This improves durability and reduces friction, improving engine performance and reliability under racing conditions.**
- **The Race Kit conrod bearing shells should be assembled in the same manner as the standard conrod bearing shells.**
- **Follow the procedure detailed in section 5 of the Daytona 675 service manual to remove the connecting rods, select the correct bearing shells for each connecting rod and refit the connecting rods.**

Main Bearing Shell

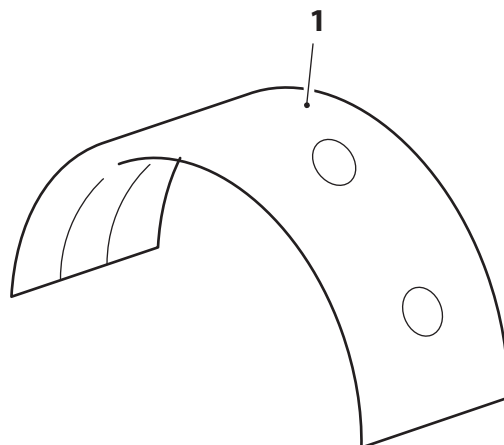

Parts supplied - A1161301

Item	Description	Thickness	Colour	Qty
1	Main bearing shell, race	1.491 mm to <1.495 mm	White	1

Parts supplied - A1161302

Item	Description	Thickness	Colour	Qty
1	Main bearing shell, race	1.495 mm to <1.499 mm	Red	1

Parts supplied - A1161303

Item	Description	Thickness	Colour	Qty
1	Main bearing shell, race	1.499 mm to <1.503 mm	Blue	1

Parts supplied - A1161304

Item	Description	Thickness	Colour	Qty
1	Main bearing shell, race	1.503 mm to <1.507 mm	Green	1

- The Race Kit main bearing shells are produced in a higher grade of alloy than the standard parts. This improves durability and reduces friction, improving engine performance and reliability under racing conditions
- The Race Kit main bearing shells should be assembled in the same manner as the standard main bearing shells.
- Follow the procedure detailed in section 5 of the Daytona 675 service manual to remove the standard bearing shells and select the correct bearing shells required.

Oil Pump Gearing Kit

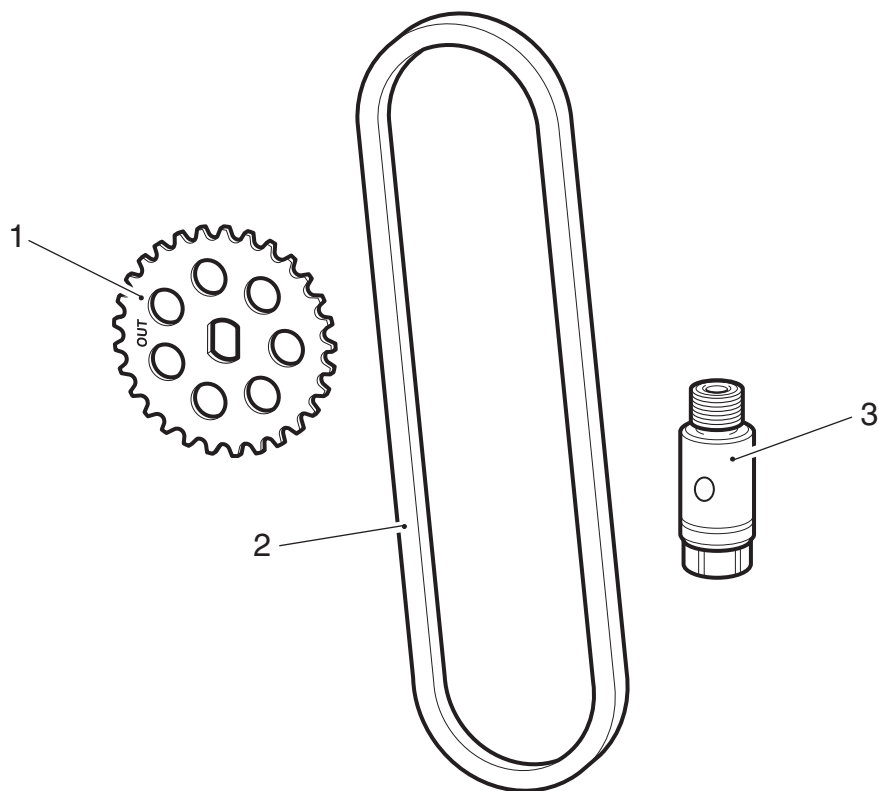

Parts Supplied - A9618096

Item	Description	Qty
1	Sprocket, oil/water pump	1
2	Chain, 76 link	1
3	Pressure release valve	1

Note:

- Refer to the appropriate sections in the **Daytona 675 service manual** to carry out the procedures outlined in steps 1 to 13.
- Remove the oil/water pump. Retain the fixings for reuse.
 - Remove the drive sprocket from the oil/water pump. Retain the fixings for reuse. Retain the sprocket if the motorcycle is to be returned to its original condition.
 - Fit the new sprocket, provided in the kit, to the oil/water pump. Apply ThreeBond 1374 thread locking compound to the fixing and tighten to **14 Nm**.

Note:

- To remove and fit a drive chain it is necessary to remove the clutch assembly.
- Remove the clutch assembly as detailed in the Daytona 675 service manual.
 - Remove the drive chain. Retain the drive chain if the motorcycle is to be returned to its original condition.
 - Fit the new drive chain. Ensure the chain runs clear within the chain guide/guard.
 - Refit the clutch assembly as detailed in the Daytona 675 service manual.
 - Refit the oil/water pump and secure with the original fixings.

-
9. Remove the original pressure release valve. Retain the valve if the motorcycle is to be returned to its original condition.
 10. Apply ThreeBond TB1305 thread locking compound to the new pressure release valve bolt thread.
 11. Fit the new pressure release valve. Tighten to **15 Nm**.
 12. Refit the sump and secure with the original fixings.

Air Funnel Kit

Caution

The use of the following Race Air Funnel Kit will require changes to the fuelling and ignition settings. To alter these settings, a Triumph Programmable Race ECU combined with Triumph TRACS Race Calibration Software will be required. Failure to correct the fuelling and ignition settings will result in poor engine performance and could result in engine damage.

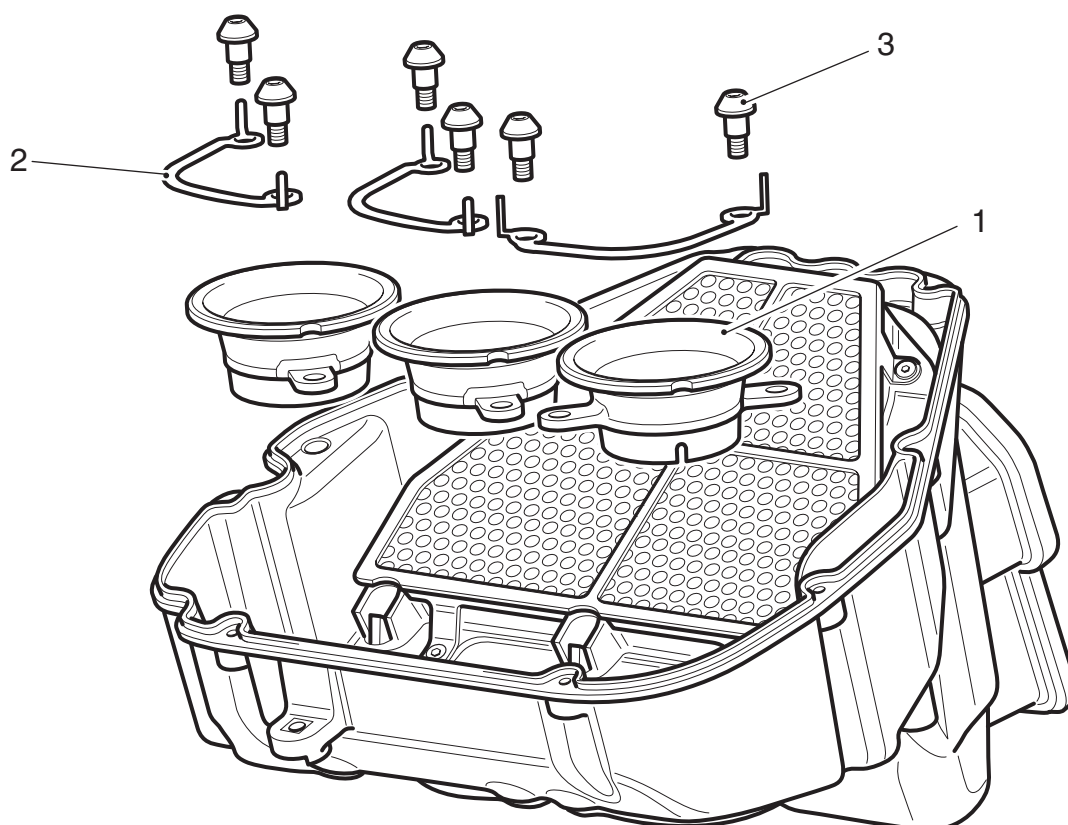

Parts supplied - A9618090

Item	Description	Qty
1	Air funnel, race	3
2	Fixing retainer	3

Note:

- It is essential that the Programmable Race ECU - A9618098 is used with the Race Air Funnel Kit to allow correct fuelling.
- The parts supplied in the Race Kit are designed to replace the standard intake air funnels located in the airbox.
- Item 3 (6 off) is the standard fixing supplied with the standard air funnel. It is not supplied in the Race Kit.

-
1. Remove the airbox lid.
 2. Remove the standard intake air funnels. Retain the fixings (2 per air funnel) for reuse.
 3. Fit the Race Kit air funnels.
 4. Fit one of the fixing retainers provided to each air funnel and retain with the original fixings. Apply ThreeBond 1364 locking compound to the threads only and tighten the fixings to a torque value of 6 Nm.

5. Fold the retention tabs, on the fixing retainers, over the 6 fixings as shown below.

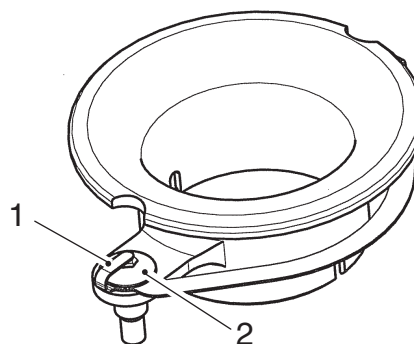

1. Retention tab
2. Fixing

Secondary Air Injection (SAI) Blanking Kit

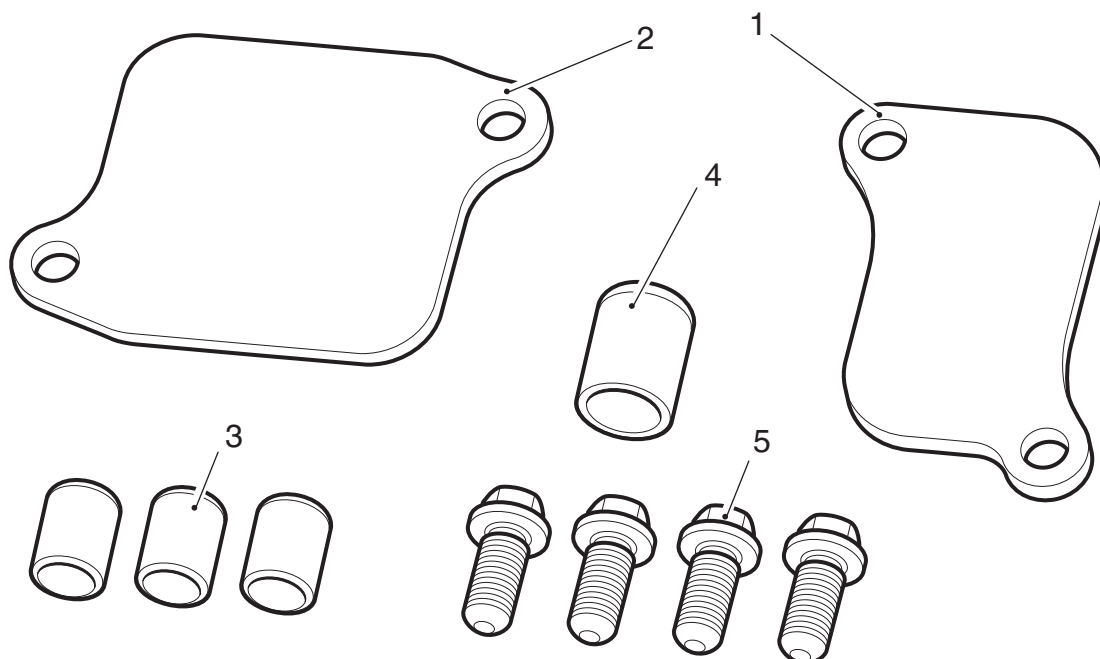

Parts supplied - A9618094

Item	Description	Qty
1	Reed valve cover, single	1
2	Reed valve cover, double	1
3	Dowel, solid	3
4	Sealing cap, airbox	1
5	Bolt, M6 x 16 mm	4

Note:

- This kit includes the necessary components to blank-off the secondary air injection channels in the cylinder head when the system is removed from the motorcycle.
- Refer to the appropriate sections in the Daytona 675 service manual to carry out the procedures outlined in steps 1 to 8.

1. Remove the SAI solenoid valve.
2. Remove the SAI reed valves.
3. Remove the camshaft cover. retain the fixings for reuse.

-
- Replace the standard hollow dowels with the solid dowels provided in the kit.

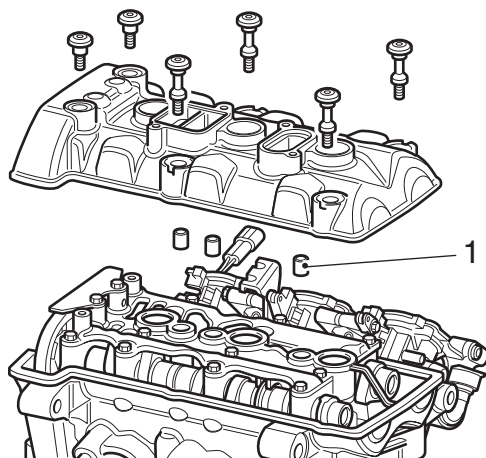

1. Dowels

- Fit a new seal to the camshaft cover. Refit the camshaft cover and secure with the original fixings.
- Fit the reed valve covers from the kit, as shown below.
- Secure with the M6 x 16 mm bolts provided. Tighten to **9 Nm**.

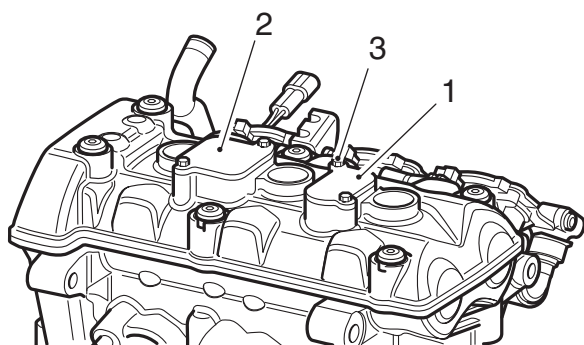

- 1. Reed valve cover, single**
2. Reed valve cover, double
3. Bolt, M6 x 16 mm

- Refit the airbox.
- Fit the sealing cap provided over the airbox hose connection, as shown below.

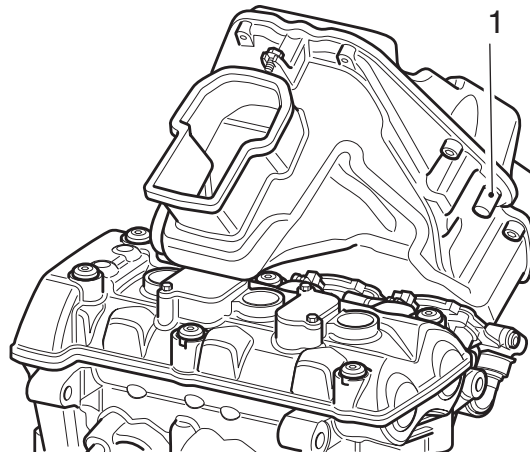

1. Sealing cap

Exhaust System, Race (Arrow)

Caution

The use of the Arrow Race Exhaust System will require changes to the fuelling and ignition settings. To alter these settings, a Triumph Programmable Race ECU combined with Triumph TRACS Race Calibration Software will be required. Failure to correct the fuelling and ignition settings will result in poor engine performance and could result in engine damage.

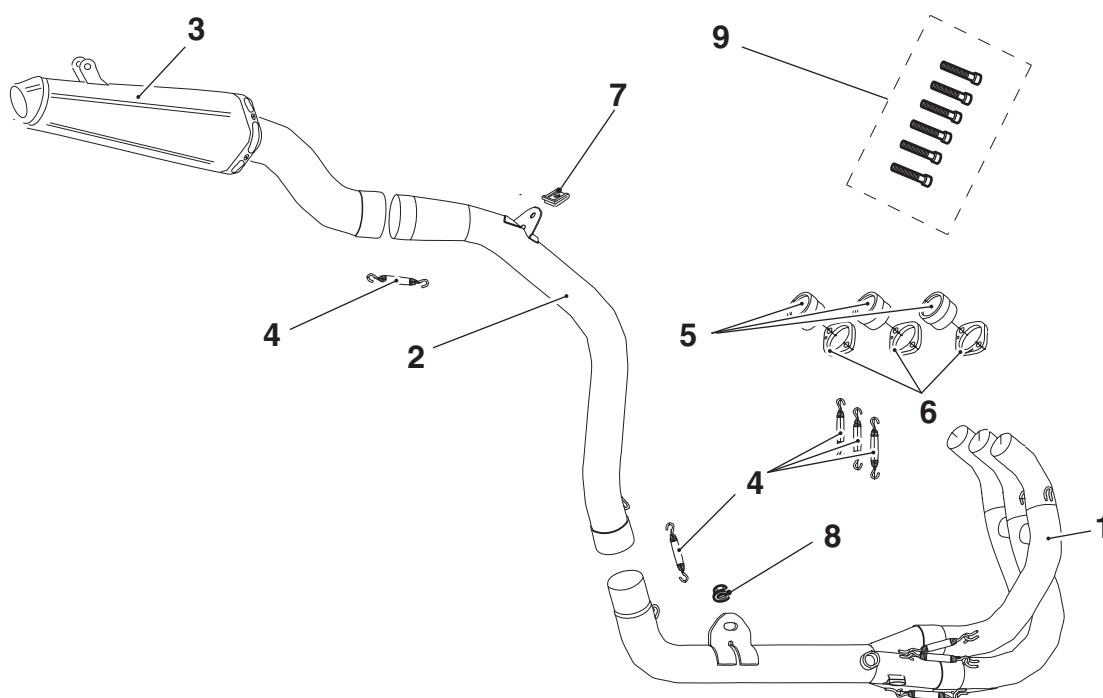

Parts supplied - A9600351

Item	Description	Qty
1	Downpipe collector assembly	1
2	Intermediate pipe	1
3	Silencer	1
4	Spring	5
5	Primary header bushing	3
6	Primary header flange	3
7	Captive nut, M8	1
8	Lock nut, M8	1
9	Capscrew, M8	6

1. Remove the seat, battery, rear bodywork, lower fairings, radiator, radiator fan, rear light, pillion foot rest hangers and exhaust system following the procedures detailed in the Daytona 675 service manual.
2. Remove the exhaust valve actuator from its actuator cables.
3. Remove and discard the exhaust gaskets and M8 studs from the cylinder head.

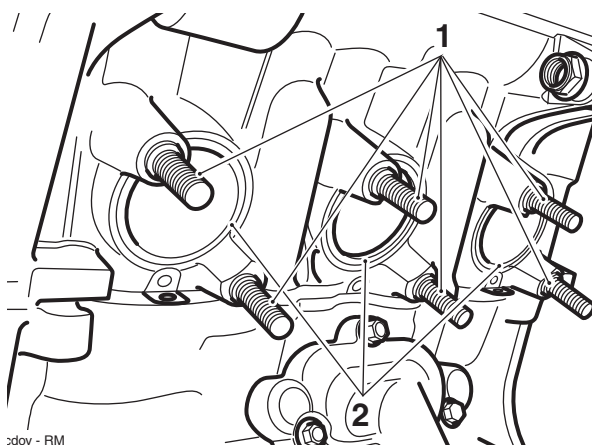

Daytona - RM

1. M8 Stud
2. Gasket

Note:

- To obtain maximum performance the exhaust port should be machined, removing material from the area shown in red. The exhaust port shape should match the inside surface of the primary header bush.

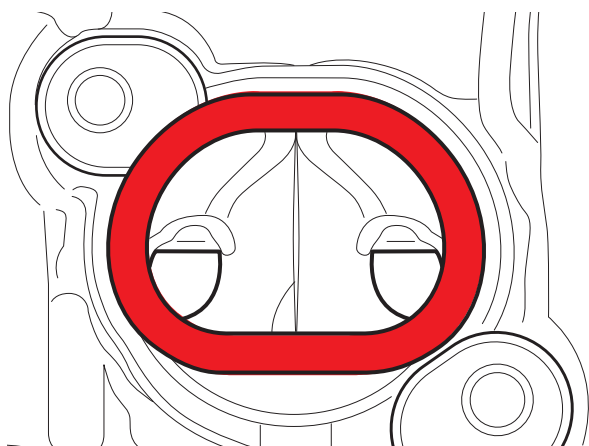

4. Thoroughly clean the mating surface of the primary header bushes and exhaust ports.
5. Apply silicone sealant to the mating surface of the primary header bush which contacts the cylinder head, the recommended sealant is Dow Corning Firestop 700 white silicone.
6. Fit the three primary header bushes to the cylinder head and secure using the primary header flanges and M8 cap screws provided.

Note:

- The primary header bush should be orientated such that none of the exhaust port is obscured by the primary header bush.

7. Position the downpipe collector assembly to the underside of the engine and insert the downpipe ends fully into the primary header bushes. Secure with the three springs provided. Ensure the spring mounting holes are positioned as shown below for all three flanges.

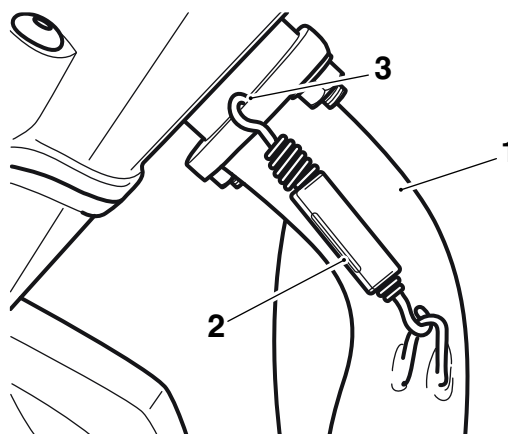

1. Downpipe
2. Spring
3. Spring mounting hole position

8. Loosely secure the assembly to the outside of the original exhaust mounting point using the original bolt and M8 locknut provided, as shown.

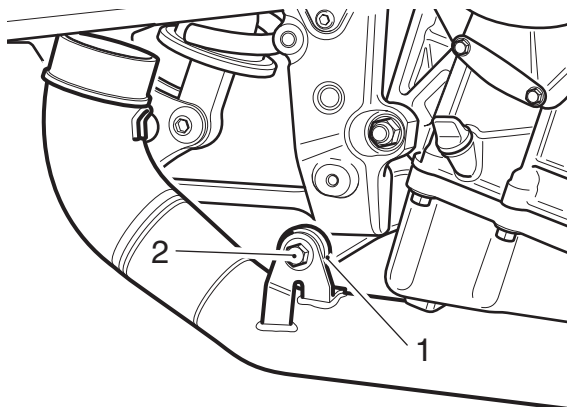

- 1. Exhaust mounting point**
2. Original bolt

9. Insert the end of the intermediate pipe into the collector pipe. Secure with the spring provided.

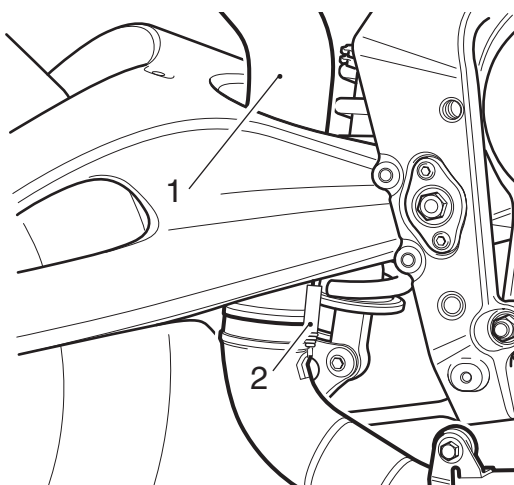

- 1. Intermediate pipe**
2. Spring

10. Attach the M8 captive nut provided to the intermediate pipe fixing point. Loosely secure the intermediate pipe to the exhaust mounting point using the original bolt, as shown.

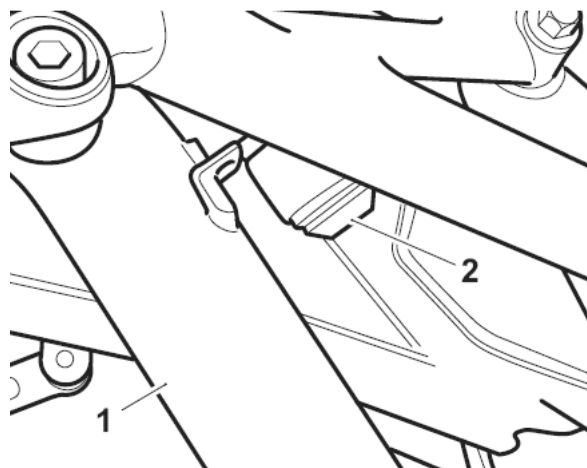

- 1. Intermediate pipe**
2. Original bolt

11. Fit the silencer to the intermediate pipe and secure with the spring provided. Loosely secure the silencer bracket/clamp to the silencer mounting point using the original fixings.

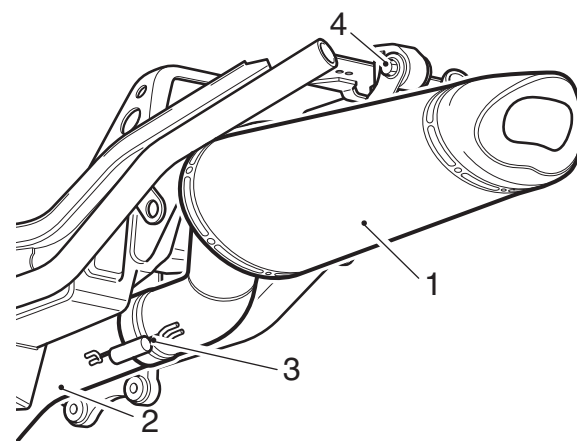

- 1. Silencer**
2. Intermediate pipe
3. Spring
4. Silencer mounting point

12. Check the exhaust system is correctly aligned with the rear frame and tighten the fixings to the following torque values:

- Rear exhaust mounting point **27 Nm**.
- Intermediate pipe mounting point fixing **22 Nm**.
- Collector pipe front mounting point fixings **27 Nm**.
- Primary header flanges, M8 cap screws **19 Nm**.

13. If fitting the oxygen sensor, remove the threaded blanking plug from the race exhaust. Fit the oxygen sensor and tighten to **25 Nm**.

14. Fit the correct specification spark plugs as recommended below.

Note:

- **Triumph recommends two options of spark plug. Choose the correct option depending on the engine compression ratio. For a standard compression ratio use NGK CR10EIX. For high compression ratio engines use NGK R0373A-10. Always ensure there is sufficient clearance between spark plug and piston, before attempting to start the engine.**

15. Refit the radiator, rear bodywork, lower fairings, battery and seat as described in the Daytona 675 service manual.

Note:

- **The radiator fan, rear light and pillion footrest hangers are NOT refitted.**

Air Filter Kit

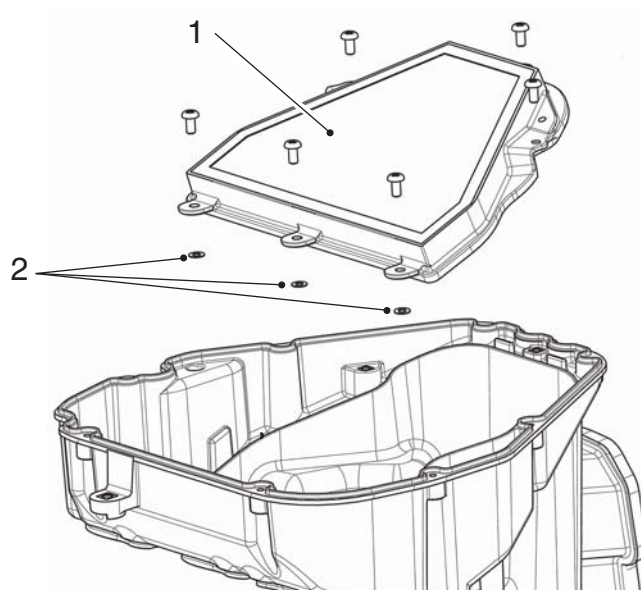

Parts supplied - A9618075

Item	Description	Qty
1	Air filter	1
2	Retaining washer	3

Note:

- This kit is supplied by BMC Air Filters. For fitment details refer to the instruction contained in the kit.
- If you have any queries with regard to the air filter kit, in the first instance contact BMC. For contact details see; www.bmcairfilters.com.
- Loctite or similar should NOT be applied to the fixings as described in the supplied instructions as this could strip the insert out of the plastic moulding when removing the filter. The kit is supplied with three plastic retaining washers to retain the fixings. The three plastic retaining washers should be fitted to the three rear fixings as shown above. Tighten the fixings to a torque value of 4 Nm.

Manual Idle Speed Adjuster Kit

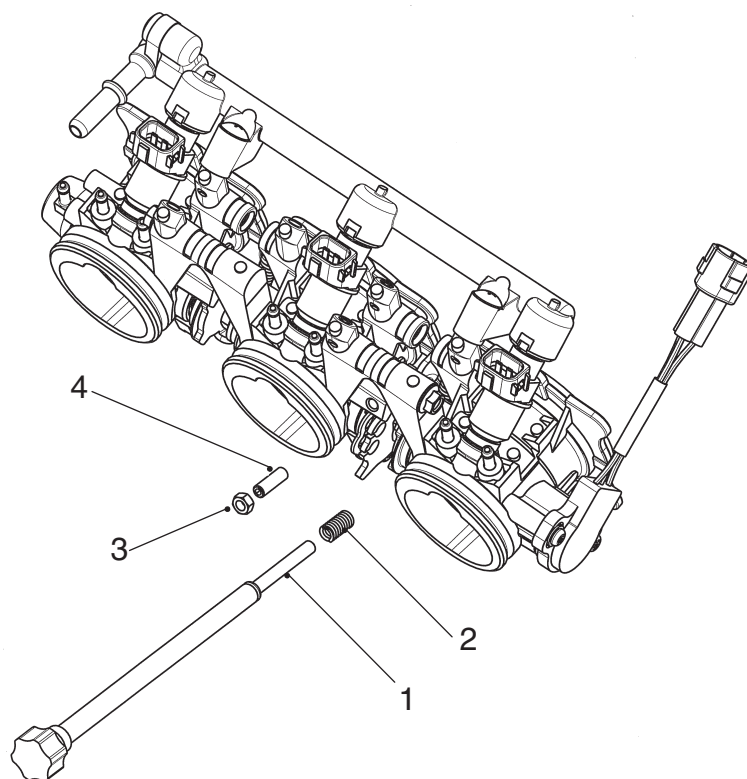

Parts supplied - A9618076

Item	Description	Qty
1	Screw, manual adjuster	1
2	Spring, compression coil	1

1. Remove the throttle body assembly following the procedure detailed in the Daytona 675 service manual.
2. Remove item 3 (M5 nut) and item 4 (throttle stop screw) from the throttle body assembly.
3. Fit the manual adjuster screw and compression spring supplied (items 1 & 2).
4. Refit the throttle body assembly following the procedure detailed in the Daytona 675 service manual.
5. Adjust the idle speed using the manual adjuster screw (item 1) as required.

Slipper Clutch Kit - A9610014

- **The Slipper Clutch Kit is supplied by STM Trading s.r.l. For fitment details refer to the instruction contained in the kit.**
- **If you have any queries with regard to the slipper clutch kit, in the first instance contact STM. For contact details see www.slipperclutch.com.**

Slipper Clutch Tool - A3880037

- **It is recommended to use the Slipper Clutch Tool when fitting the Slipper Clutch.**

Detent Wheel Kit

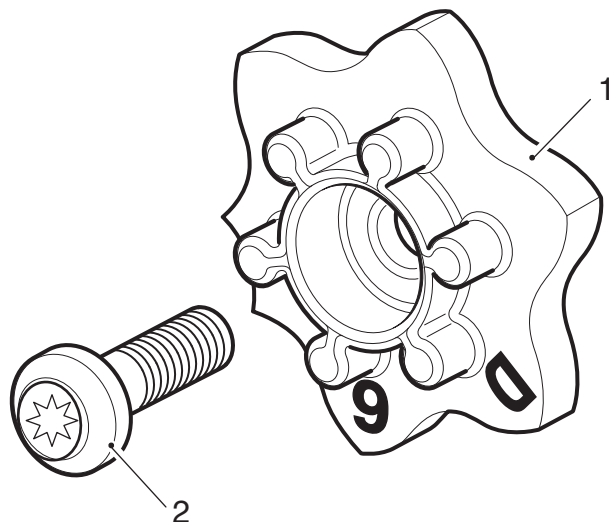

Parts supplied - A9618068

Item	Description	Qty
1	Detent wheel	1
2	Screw, Torx head, M6 x 20, black	1

1. Remove the clutch as described in section 5 of the Daytona 675 service manual.
2. Release the two fixings and remove the baffle plate from the crankcase breather. Discard the fixings.

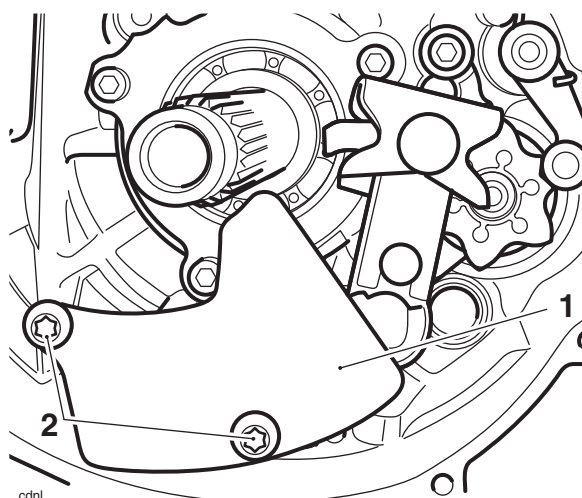

- cdnl
1. Crankcase breather baffle plate
 2. Fixings

3. If not already removed, note the position and orientation of the gear pedal crank in relation to the shaft, then remove the crank.
4. Remove the E-clip and washer from the gear pedal end of the gear change shaft.

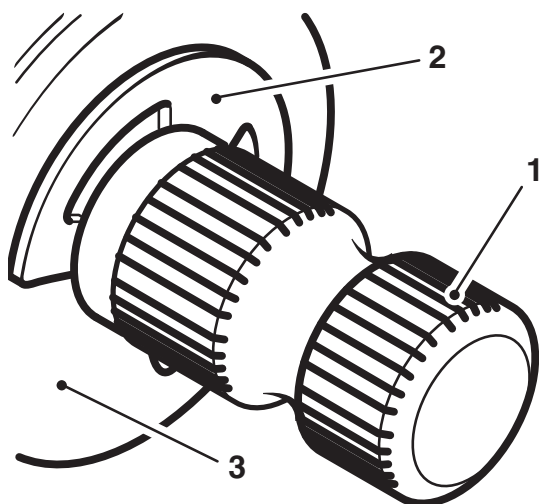

1. Gear change shaft
2. E-clip
3. Washer

5. Withdraw the gear change shaft from the clutch end of the crankcase.

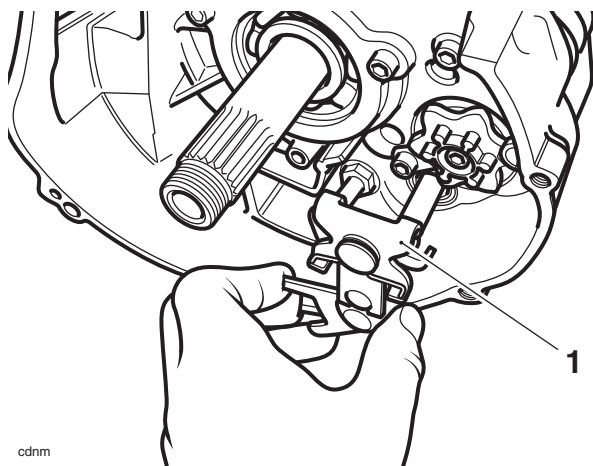

1. Gear change shaft

Note:

- **The detent arm is held in position under spring pressure. Prior to removal, note the orientation of the detent arm, fixing and spring, relative to the selector drum detent wheel. The same orientation must be retained on assembly.**

6. Release and remove the fixing securing the detent arm.

7. Withdraw the detent arm complete with its flanged sleeve, spring and washer.

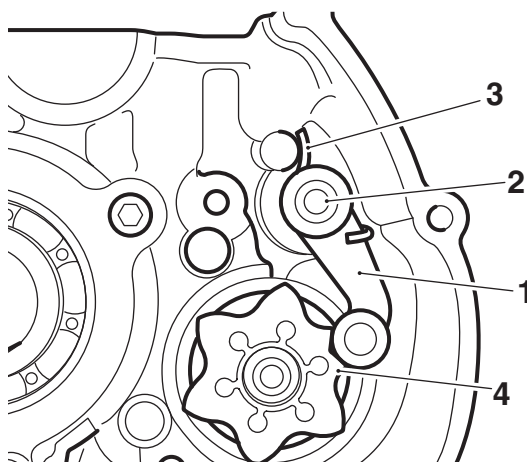

1. Detent arm
2. Fixing
3. Spring
4. Detent wheel

8. Remove the existing detent wheel and fixing from the selector drum assembly, note how the detent wheel is timed relative to the selector drum by way of a dowel.
9. Assemble the Race Kit detent wheel to the selector drum assembly, ensuring it is timed to the drum in the same way as the original detent wheel.
10. Fit the M6 Torx head screw to the selector drum assembly and tighten to **12 Nm**. Ensure the detent wheel is fully inserted into the bearing, up to its shoulder.

- Assemble the detent arm as noted on removal and place up to the crankcase.

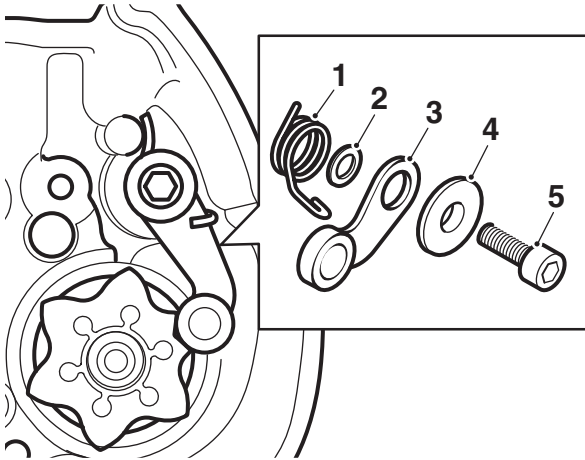

- Spring
- Washer
- Detent arm
- Flanged sleeve
- Fixing

- Hold the detent arm assembly in position and insert a new fixing. Start the thread and push the detent arm, using finger pressure only, to locate on the selector drum detent wheel.
- Ensure the detent arm remains correctly located on the detent wheel and the spring is correctly seated in the recess in the crankcase. Ensure the shoulder of the flanged sleeve is located in the bore detent arm. Tighten the fixing to **12 Nm**.

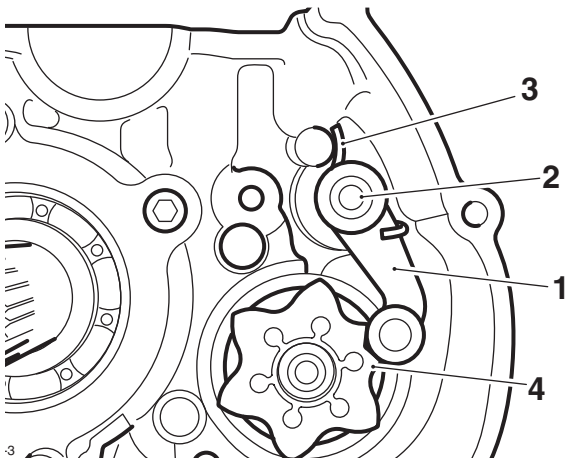

- Detent arm
- Fixing
- Spring
- Selector drum detent wheel

- Rotate the selector drum to the neutral position. Ensure that the detent arm locates in the raised profile in the detent wheel (neutral position).

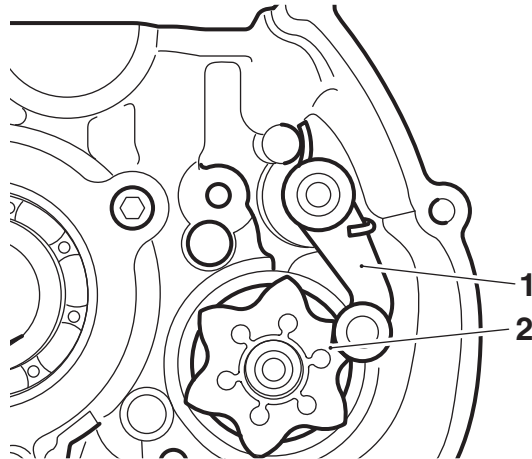

- Detent arm
- Neutral position

- Using clean engine oil, lubricate the lip of the seal on the gear change shaft.

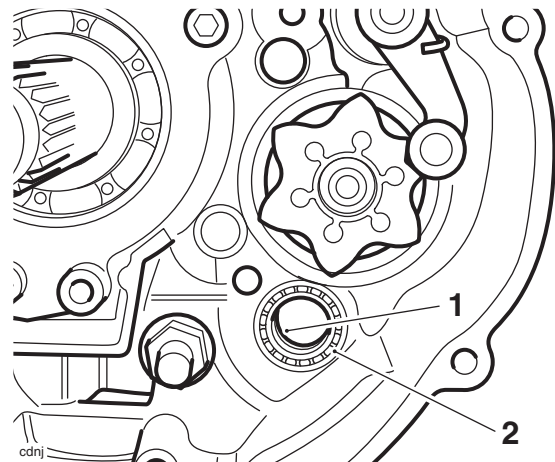

- Gear change shaft seal
- Gear change shaft bearing

Caution

Take care to avoid damaging the lip of the seal when inserting the gear change shaft into the crankcase. A damaged seal will lead to oil loss and could result in engine damage.

16. Insert the gear change shaft into the crankcase. Gently push the gear pedal end of the shaft through the bearing and lip seal at the clutch side of the crankcase, and the sealed bearing, located at the gear pedal side of the crankcase.

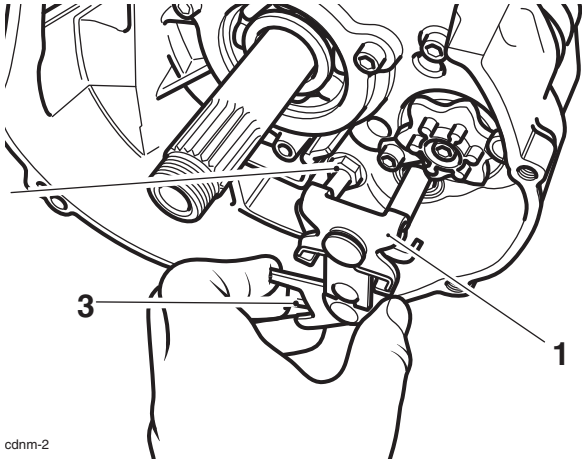

cdnm-2

1. Gear change shaft
2. Abutment bolt
3. Spring

17. Ensure that the gear change shaft fingers locate in the detent wheel/arm and that the spring fits either side of the abutment bolt.
18. Fit the washer and E-clip to the gear pedal end of the gear change shaft.

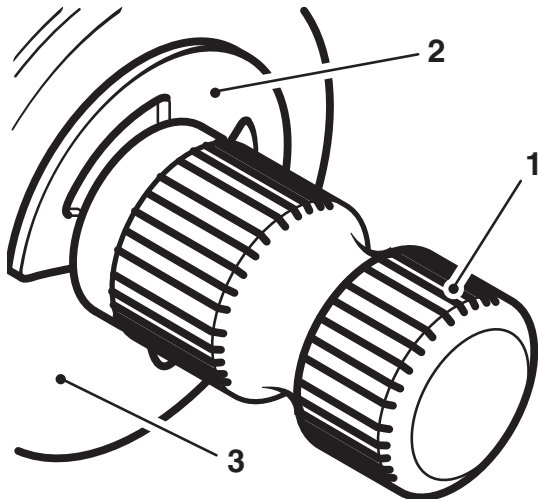

1. Gear change shaft
2. E clip
3. Washer

19. Fit the gear pedal crank to the shaft in the same orientation as noted prior to removal. Ensure the dot mark on the shaft aligns with the split line on the gear pedal crank. Tighten the fixing to **9 Nm**.
20. Incorporating new fixings, refit the baffle plate to the crankcase breather. Tighten the fixings to **9 Nm**.
21. Refit the clutch and clutch cover as detailed in section 5 of the Daytona 675 service manual.

Cooling Silicon Hose Kit

Parts Supplied - A9618127

Item	Description	Qty
1	Hose set, silicon	1
2	Clip, 10.5 ger oetker	1
3	Clip, hose, dia 14.0 - 22.0	4
4	Clip, hose, dia 24.0 - 32.0	5
5	Clip, hose, dia 27.0 - 35.0	1
6	Clip, hose, dia 11.0 - 12.5	2

1. Tighten the clamps for the silicon hoses to **2 Nm**.
2. Refer to the service manual for more information.

Electrical Parts

Race Alternator Kit

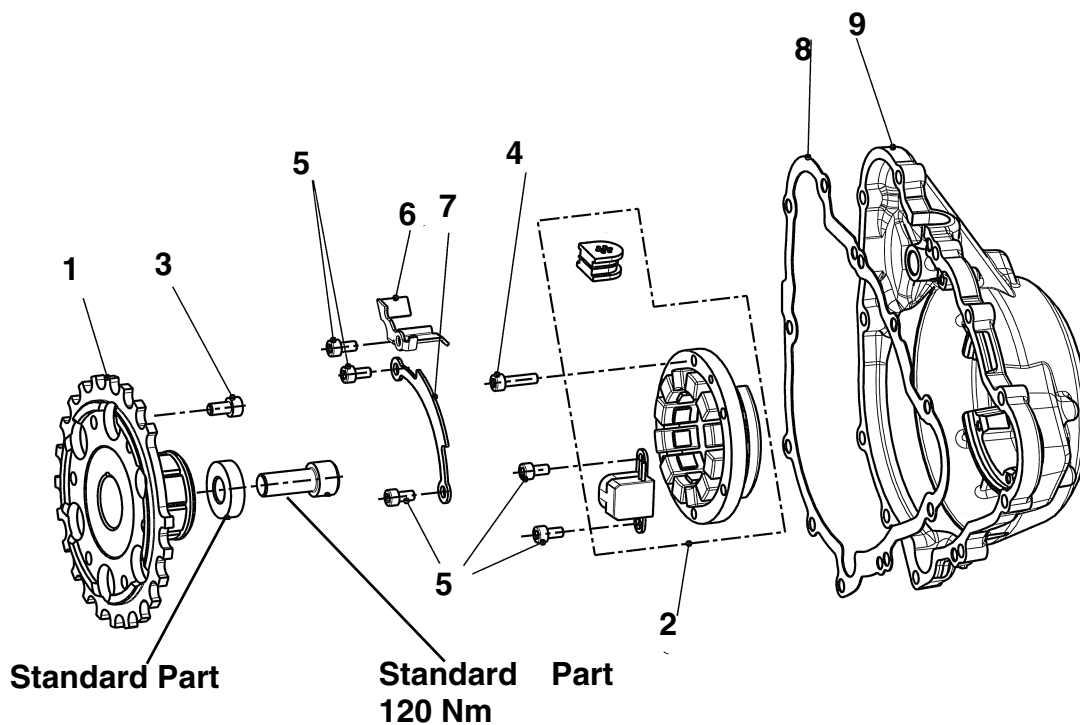

Parts supplied - A9618069

Item	Description	Qty
1	Rotor, race ACG	1
2	Stator, race ACG (includes crank sensor)	1
3	Screw, caphead, M6 x 1 x 12, ENC (to retain sprag clutch housing)	6
4	Screw, skt hd cap, M5 x 0.8 x 20	6
5	Screw, skt hd cap, M5 x 0.8 x 10	5
6	Plate, wire retainer	1
7	Plate, wire retainer	1
8	Gasket, alternator cover (standard part)	1
9	Cover, alternator (unpainted sand casting)	1

Alternator Puller Tool - A3880206

Item	Description	Qty
1	Puller tool, alternator	1

1. Remove the alternator as described in section 17 of the service manual.
2. Remove the starter drive gear and sprag clutch from the alternator rotor as described in section 7 of the service manual. Discard the original fixings.
3. Using the M6 x 12 mm screws provided (3), fit the sprag clutch and starter drive gear to the race rotor (1) following the procedure detailed in section 7 of the service manual.
4. Remove all grease and oil from the taper surfaces on both the crankshaft and rotor before assembly.
5. Assemble the race rotor and sprag clutch assembly to the crankshaft following the procedure detailed in section 17 of the service manual.
6. Using the M6 x 20 mm screws provided (4), assemble the race stator (2) to the alternator cover provided (9). Tighten to **6 Nm**.
7. Apply silicone sealant to the cable grommet (ThreeBond 1215 is recommended), and align the cable to the exit slot.
8. Using two of the M5 x 10 mm screws provided (5), assemble the crankshaft sensor to the alternator cover. Tighten to **6 Nm**.
9. Fit the wire retaining plates (6 & 7) to the alternator cover and secure with the remaining M5 x 10 mm screws provided (5). Tighten to **6 Nm**.
10. Position the new gasket provided (8) to the crankshaft dowels, then fit the race alternator cover and stator assembly to the crankcase following the procedure detailed in the service manual.

Rotor removal - Race ACG



Caution

Do not use tools of any kind to tighten the service tool T3880375. Tighten the tool by hand only. Over-tightening of the service tool will lead to damage of the alternator rotor.

1. Clean the alternator rotor removing all traces of oil.
2. Fit the service tool T3880375 to the outside diameter of the rotor. Retain the tool to prevent the crankshaft from rotating and remove the centre bolt from the crankshaft.
3. With the crankshaft bolt removed, locate the spigot of the thrust pad supplied with service tool A3880206 into the end of the crankshaft.
4. Assemble the threaded portion of service tool A3880206 into the threaded portion of the rotor. Ensure the thrust pad does not fall out during assembly of the service tool.
5. Hold the service tool T3880375 to prevent rotation of the rotor, then tighten service tool A3880206 to release the taper seating of the rotor from the crankshaft.
6. Withdraw the rotor and service tools as an assembly and then separate the tools from the rotor. Collect the woodruff key and the service tool thrust pad from the crankshaft.

Programmable Race ECU



Warning

The Programmable Race ECU MUST be used with the following Race Kits; A9618055 Camshaft - Inlet, A9618056 Camshaft - Exhaust, A9618095 Camshaft Sprocket, A9618061 Inlet & Exhaust Valves, A9618086 Valve Spring Kit, A9600351 Arrow Race Exhaust System, A9618090 Air Funnel Kit and A9618100 Race Harness.

Part supplied - A9618098

Item	Description	Qty
1	Programmable Race ECU	1

Note:

- The Programmable Race ECU will only work with the Race Harness A9618100.
- The Programmable Race ECU is pre-programmed for use with the following set of Race Kits: Inlet & Exhaust Camshafts, Camshaft Sprocket Kit, Inlet & Exhaust Valves, Air Filter Kit, Air Funnel Kit and Arrow Race Exhaust System. The tune has been developed to suit a compression ratio of 14:1 with enlarged and polished inlet ports and the exhaust ports modified as recommended on page 23. However, due to variation between race prepared engines fuelling adjustments will be required.
- The tune is for motorcycles fitted with a rubber fuel hose only, Triumph Part No. 1240177, it is NOT suitable for motorcycles fitted with a plastic fuel hose.
- The air/fuel ratio and ignition timing should be checked. Any adjustments to the fuelling or ignition settings should be made using the Triumph TRACS Race Calibration Software (see page 38).
- The rev limit on the race ECU has been increased from 13900 rpm to 14500 RPM.
- The indicated speed shown on the instruments is calibrated for the standard gearbox. If the final drive ratio is changed, the indicated speed will be incorrect.
- Idle speed should be set to between 1,500 and 1,800 RPM.

ECU Malfunction indicator light

- This will flash a sequence of error codes if any faults are present.
- Flash codes have a long flash for the first digit and a short flash for the second digit. For example; fault code "32" would be: long, long, long, short, short.
- When a fault has been identified and rectified, the ECU can be cleared by the following sequence: full throttle, ignition ON; flick the engine stop switch off/on/off/on/off.



Caution

No ECU faults should be present during motorcycle operation. If the motorcycle is used with ECU faults present it will be operating in default 'limp home' mode only which will produce inconsistent operation.

Fault Code Table

Flash Code	Problem
02	Crank sensor
33	Number 1 injector
34	Number 2 injector
35	Number 3 injector
37	Number 1 ignition coil
38	Number 2 ignition coil
39	Number 3 ignition coil
06	Throttle position sensor
09	MAP sensor
68	MAP sensor pipe disconnected
12	Coolant sensor
13	Air temperature sensor
14	Atmospheric air pressure sensor
41	Fuel pump
65	EEPROM error
26	5v sensor supply problem
15	Roll over sensor
22	Gear position sensor
24	Ignition switch circuit problem
25	Battery voltage supply problem
43	Cooling fan relay
44	Airflap solenoid
66	Instrument communication error
70	Vehicle speed sensor
67	Main relay
Continuous Short Flash	Harness or instruments

Triumph Race Calibration Software (TRACS)

Parts supplied - A9610051

Item	Description	Qty
1	TRACS software CD	1
2	Diagnostic plug connector	1
3	USB lead	1

Note:

- **TRACS is a computer program which allows all Triumph Daytona 675 Programmable Race ECUs to be tuned using a laptop computer.**
- **The TRACS software is supplied with a diagnostic plug connector and a USB lead to allow connection to the ECU using the dedicated diagnostic plug on the motorcycle.**
- **Features include:**
 - Fully programmable fuel mapping.
 - Fully programmable ignition mapping.
 - Switchable wet and dry ignition maps.
 - Adjustable pit lane speed limiter and speedometer calibration.
 - Adjustable Quickshifter cut duration.
 - Adjustable rev-limiter up to 15,000 rpm.
 - Improved software strategies to improve throttle progression.
 - Optimised software, to cater for higher engine speeds involved in a race environment.
 - Unlimited ability to save multiple maps on a PC's hard drive.
- **TRACS is compatible with Windows XP (Service Pack 2 and above) and Vista operating systems only.**
- **Minimum system requirements: 200MHz or higher Pentium compatible CPU. 64 MB RAM, 300 MB hard drive space.**
- **TRACS software is suitable for use with Triumph Programmable Race ECU A9618098 (marked 'Part 1290676') and Triumph Programmable Race ECU A9618070 (marked 'Part 1290675').**
- **To gain use of the pit lane speed limiter and wet/dry ignition map functions, the motorcycle must be equipped with Race Harness Kit A9618100.**
- **Refer to the user instruction files on the software CD supplied.**

TRACS Management Kit (Programmable Race ECU and Race Calibration Software Bundle)

Parts supplied - A9618099

Item	Description	Qty
1	TRACS software CD	1
2	Diagnostic plug connector	1
3	USB lead	1
4	Programmable Race ECU	1

Note:

- **Refer to the user instruction files on the software CD supplied.**

Race Harness Kit

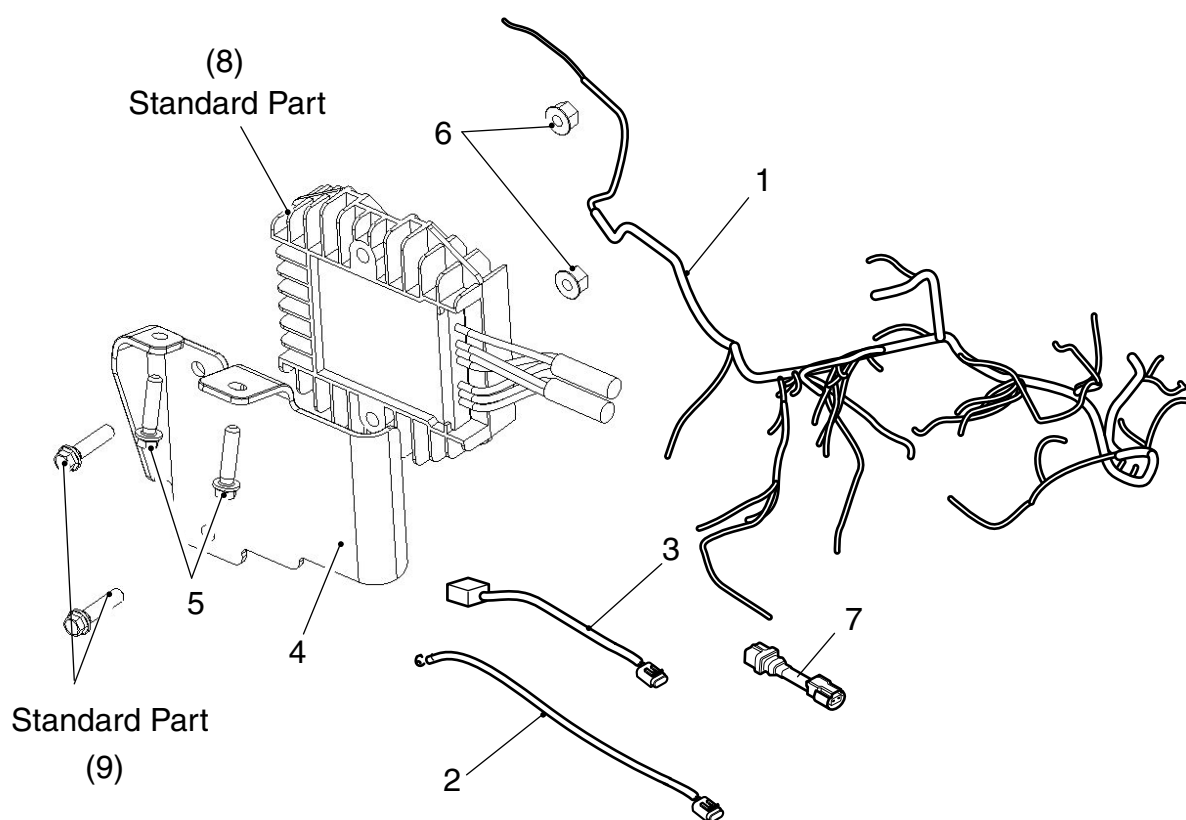

Parts supplied - A9618100

Item	Description	Qty
1	Main harness, race	1
2	Connector, custom quickshifter (2 wires)	1
3	Connector, pit lane speed limiter and wet/dry map (4 wires)	1
4	Regulator bracket	1
5	Bolt, M6 x 25 mm	2
6	Locknut, M6	2
7	Sub-harness, air temperature sensor	1
8	Rectifier/regulator	1
9	Bolt, M6 x 25 mm	2

Note:

- The Race Harness will not work without the Programmable Race ECU A9618098, or Race ECU A9618070 updated using the TRACS system.
- The regulator unit (item 8) must be relocated from its original position, within the fairing, to a new position on the frame adjacent to the swing arm pivot. This is to allow fitment of race bodywork. The original fixing bolts (item 9) should be retained for reuse.

1. Remove the regulator from the original bracket, retain the bolts for reuse. Discard the bracket and lock nuts.
2. Secure the regulator unit (8) to the new regulator bracket provided (4), using the original bolts (9) and M6 lock nuts provided (6). Tighten the fixings to **12 Nm**.
3. Secure the regulator bracket to the motorcycle frame using the M6 x 25 mm bolts provided. Tighten the fixings to **12 Nm**.

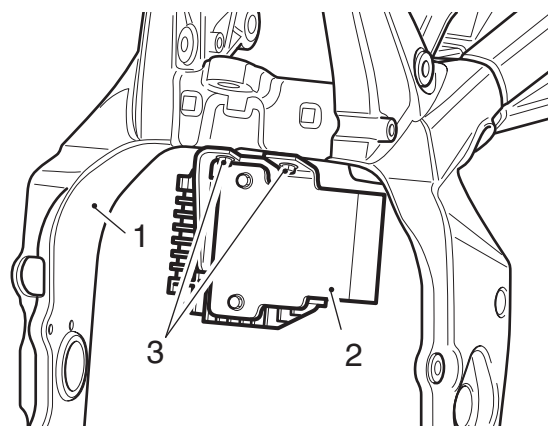

1. Frame
2. Regulator bracket
3. Bolts, M6 x 25 mm

Note:

- **The alternator will now plug directly into the regulator.**
- **The relay and fuse box position has changed on the race harness for ease of access and maintenance. They are now located alongside the battery, under the seat. Ensure they are secured in position so they do not suffer from vibration problems.**
- **The Race Harness does not support all of the original equipment, therefore, the following components can be removed from the motorcycle; oxygen sensor, exhaust valve, idle speed control, secondary air injection (SAI), purge control valve and evaporative canister (California only), lights and air intake flap solenoid. The SAI ports must be blocked off with SAI Blanking Kit A9618094 if the system is removed. The throttle body purge ports must also be blocked off before use (California only).**
- **The Race Harness still supports the cooling fan and incorporates a relay for the fan. You may remove the cooling fan but must leave the relay in place.**
- **The Race Harness does not support the idle speed control motor and therefore, this may be removed from the throttle body. It is recommended to use the Manual Idle Speed Adjuster A9618076 to replace the throttle stop screw when using the Race Harness. Throttle body balance should be checked if the ISC cam is removed from the throttle body assembly.**
- **The Race Harness is suitable for use with both the standard and Race Kit alternator. It is recommended to always run an alternator, without it the battery will discharge in a very short period of time.**
- **Sub-harness - There are two options of air temperature sensors. Earlier models will connect directly to the air temperature sensor. For later models an adapter harness will be required, this is included in the kit.**

Quickshifter

- The combination of the programmable race ECU and race harness allows the ability to have ignition cut for 'quick shift'. It is recommended to use the following kits; A9930224 - Quickshifter, Race, Standard Shift, or A9930225 - Quickshifter, Race, Reverse Shift. The default cut time is 40ms. By using the Triumph TRACS Race Calibration Software, the cut time for low, medium and high engine speeds can be individually adjusted.
- Alternatively, a custom quickshifter can be installed. To use this option, connect a suitable switch to the supplied connector (2). Mount the switch in a convenient position. The connector plugs into a 2-pin connector fitted with a blanking plug. The minimum rating for the switch is 2mA at 5V.

Custom Quickshifter (2 wire connection)			
Wire Colour	Polarity	Function	ID Tape
black/red	+	Custom Quickshifter	None
black	-		

- If a quickshift function is not going to be used, leave the harness connector blanked off to prevent a possible short circuit.

Wet/dry map and pit lane speed limiter

- The combination of race harness, programmable race ECU and Triumph TRACS Race Calibration Software provides the ability to select different engine maps for wet and dry conditions and also activate a pit lane speed limiter.
- To utilise the wet/dry map feature, connect a suitable 'on/off' switch to the supplied connector (3). The correct wires on the connector are identified by red ID tape (black wire and white/blue wire). The minimum rating for the switch is 110mA at 14V.
- To utilise the pit lane speed limiter feature, connect a suitable 'push to make' switch to the supplied connector (3). The correct wires on the race harness are identified by yellow ID tape (purple/black wire and pink/brown wire). The minimum rating for the switch is 0.5mA at 14V.

Wet/dry map and pit lane speed limiter (4 wire connector)			
Wire Colour	Polarity	Function	ID Tape
white/blue	+	Wet/dry map	Red
black	-		
pink/brown	+	Pit lane speed limiter	Yellow
purple/black	-		

-
- **The wet/dry map and pit lane speed limiter connector plugs into the 4-pin connector fitted with a blanking plug.**
 - **If either the wet/dry map only function, or pit lane speed limiter only function is to be used, the remaining unused wires on the connector must be insulated with tape in such a way that the wire ends are protected from each other, and any other motorcycle component to prevent a possible short circuit.**
 - **If neither the wet/dry map or pit lane speed limiter functions are going to be used, leave the harness connector blanked off to prevent a possible short circuit.**
 - **To avoid false triggering in wet conditions, all switches used should be of a sealed type.**
 - **Do not connect the black wire to the pink/brown wire on the race harness in any circumstances as this will result in a short circuit.**

Chassis Parts

Quickshifter, Race

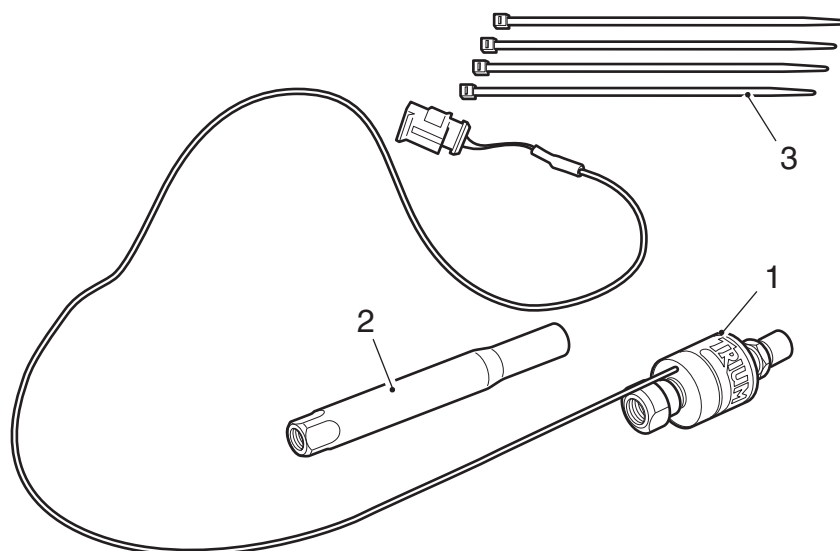

Parts supplied - Standard Shift - A9930224

Item	Description	Qty
1	Quickshifter sensor	1
2	Gear selector rod	1
3	Cable tie	4

Note:

- This part is suitable for fitment to Arrow Rearsets A9750539 only.
- For fitment, refer to the comprehensive fitting instructions supplied with the quickshifter.

Parts supplied - Reverse Shift - A9930225

Item	Description	Qty
1	Quickshifter sensor	1
2	Gear selector rod	1
3	Cable tie	4

Note:

- This part is suitable for fitment to Arrow Rearsets A9750536 only.
- For fitment, refer to the comprehensive fitting instructions supplied with the quickshifter.

Rearsets, Race, Reverse Shift (Arrow)

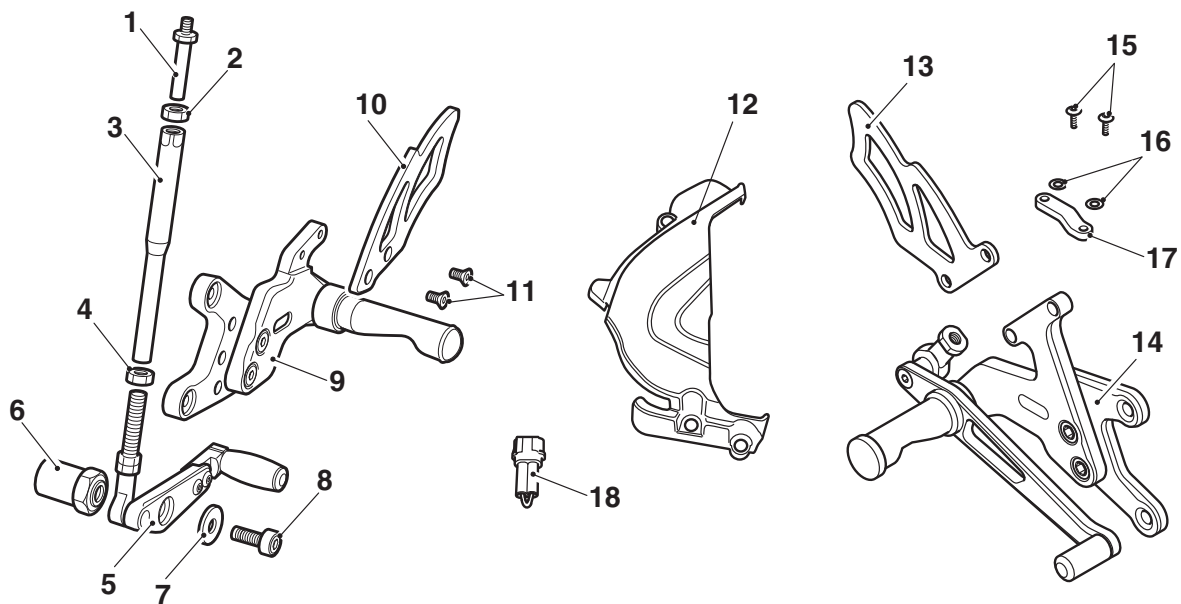

Parts Supplied - A9750536

Item	Description	Qty
1	Adapter, M6 to M8 - left hand thread	1
2	Nut, M8 - left hand thread	1
3	Gear selector rod	1
4	Nut, M8 - right hand thread	1
5	Gear change lever assembly	1
6	Mounting spacer	1
7	Bearing cap	1
8	Screw, M8	1
9	Footrest mounting assembly - left hand side	1
10	Heel guard - left hand side	1
11	Screw, M5	2
12	Sprocket cover	1
13	Heel guard - right hand side	1
14	Footrest mounting assembly - right hand side	1
15	Screw, M6	2
16	Washer, M6	2
17	Support, rear brake fluid reservoir	1
18	Shorting plug	1

Notice

This accessory kit is for racing only. It is to be used solely during closed-course racing and with the side stand removed. A motorcycle fitted with this kit and with the side stand removed must not be used on public roads. It is illegal to use a motorcycle fitted with this kit on public roads. A motorcycle fitted with this kit does not comply with local laws and regulations. If you use a motorcycle fitted with this kit on public roads, you may be prosecuted.

Warning

This accessory kit is designed for use on Triumph Daytona 675 motorcycles only and should not be fitted to any other Triumph model or to any other manufacturer's motorcycle. Fitting this accessory kit to any other Triumph model, or to any other manufacturer's motorcycle, may interfere with the rider and could affect the handling, stability or other aspects of the motorcycle's operation which may result in loss of motorcycle control and an accident.

Warning

Always have Triumph approved parts, accessories and conversions fitted by a trained technician of an authorised Triumph dealer. The fitment of parts, accessories and conversions by a technician who is not of an authorised Triumph dealer may affect the handling, stability or other aspects of the motorcycle's operation which may result in loss of motorcycle control and an accident.

Warning

Throughout this operation, ensure that the motorcycle is stabilised and adequately supported on a paddock stand to prevent risk of injury from the motorcycle falling.

Warning

A torque wrench of known accurate calibration must be used when fitting this accessory kit. Failure to tighten any of the fasteners to the correct torque specification may affect motorcycle performance, handling and stability. This may result in loss of motorcycle control and an accident.

Warning

The side stand must be removed when this accessory kit is fitted to the motorcycle. Operating the gear change lever from this accessory kit with the side stand fitted will restrict the movement of the gear change lever. Operating the gear change lever with restricted movement may result in loss of motorcycle control and an accident.

Note:

- **Before fitting this accessory kit, ensure the owner of the motorcycle has been informed of the warnings contained in these instructions.**

Left Hand Footrest and Mounting Assembly

1. Remove the rider's seat as described in the service manual.
2. Disconnect the battery, negative (black) lead first.
3. Remove the fuel tank as described in the service manual.

Note:

- **The ball joint and locknut on the transmission linkage have a left hand thread. This is identified by a machined ring on the gear selector rod.**
4. Loosen the locknut at the ball joint on the transmission linkage.

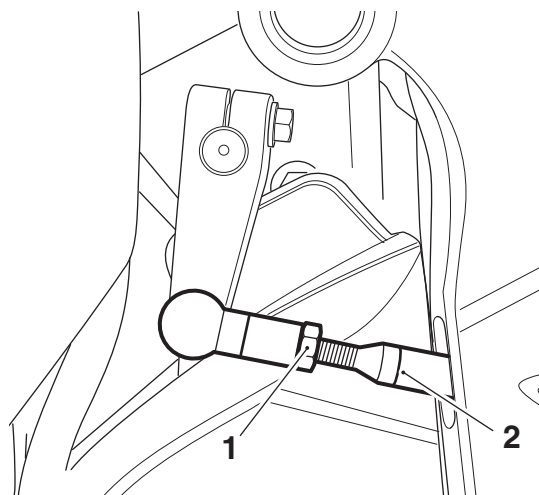

cffl_5

1. Locknut
2. Machined ring, left hand thread identification

5. Remove the wire clip retaining the ball joint to the gear change lever and detach the ball joint. Retain the wire clip if the motorcycle is to be returned to its original condition.

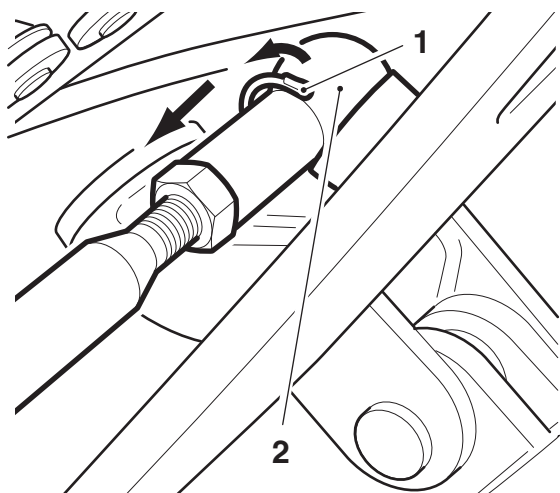

1. Wire clip
2. Ball joint

6. Remove the wire clip retaining the ball joint to the transmission linkage, detach the ball joint and remove the gear selector rod. Retain the wire clip for re-use.

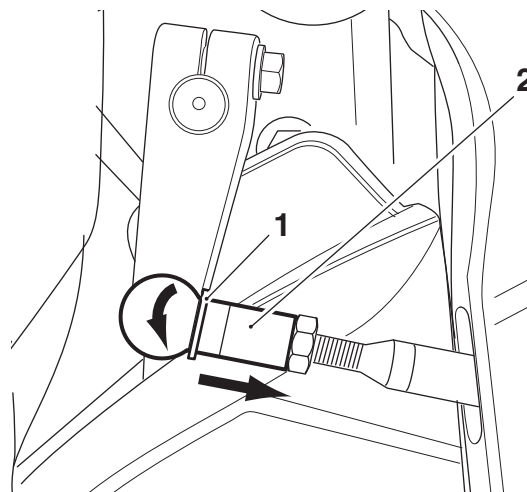

1. Wire clip
2. Ball joint



Caution

It may be difficult to remove the original ball joint from the gear selector rod. Do not use excessive force. If necessary, apply a releasing oil to the ball joint threads to aid removal.

7. Unscrew the gear selector rod from the transmission linkage ball joint. Retain the gear selector rod if the motorcycle is to be returned to its original condition.

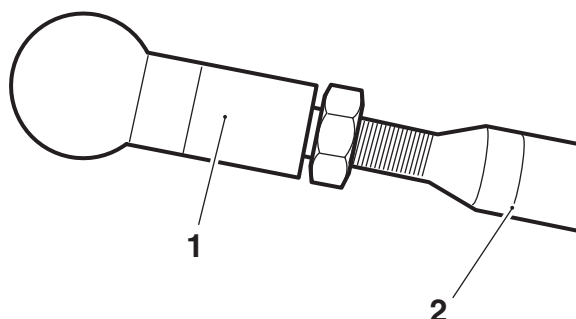

cffl_4

1. Ball joint
2. Gear selector rod

Note:

- **The ball joint on the transmission linkage and the M6 to M8 adapter have a left hand thread.**

8. Fit the M8 nut, left hand thread, fully onto the M6 to M8 adapter.
9. Attach the M6 to M8 adapter to the transmission linkage ball joint. Do not fully tighten at this stage.
10. Remove the two screws and the left hand footrest mounting assembly. Retain the screws for re-use. Retain the footrest mounting assembly if the motorcycle is to be returned to its original condition.

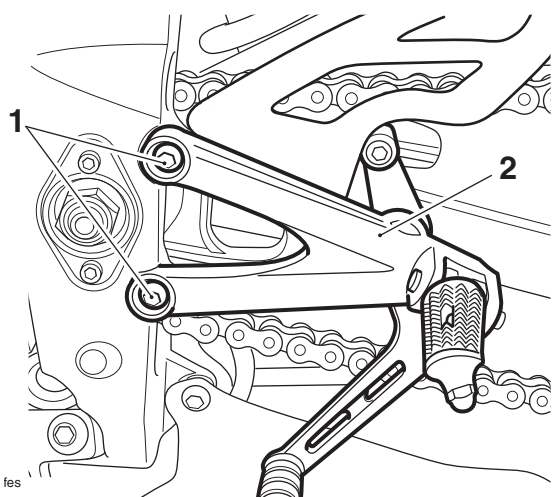

1. Screws
2. Footrest mounting assembly

Note:

- **The main harness connector for the side stand switch connector is located under the fuel tank and can be identified by the white tape on the harness.**

11. Follow the route of the side stand switch harness to its connection with the main harness.

12. Disconnect the side stand switch from the main harness.

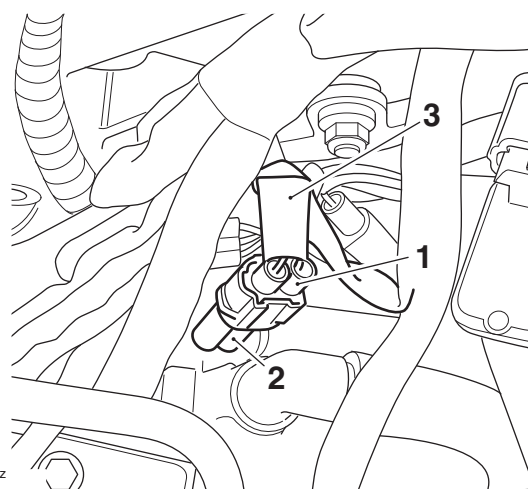

1. Main harness connector
2. Side stand connector
3. White tape

13. Remove the bolts and washers securing the side stand to the frame. Retain the bolts and washers if the motorcycle is to be returned to its original condition.

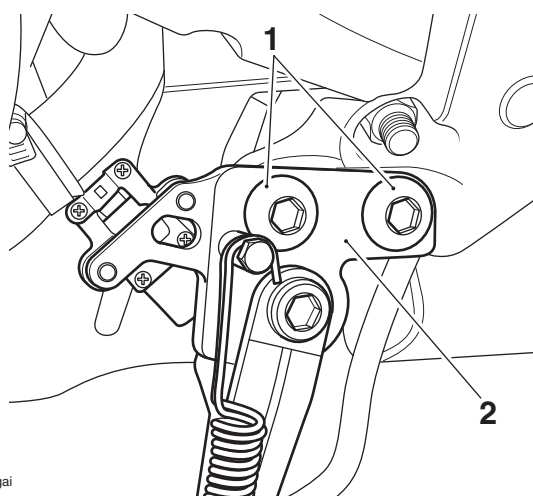

1. Bolts
2. Side stand

14. Carefully feed the side stand switch harness down the frame and remove the side stand. Retain the side stand if the motorcycle is to be returned to its original condition.

Note:

- **An audible click can be heard when the shorting plug is fully fitted.**

15. Fit the shorting plug from the kit to the main harness connector.

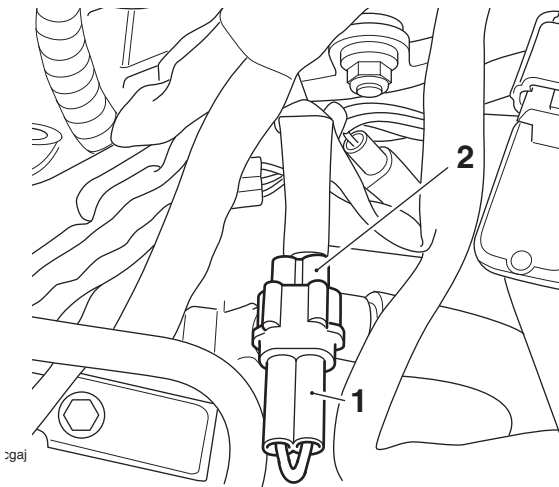

1. Shorting plug
2. Main harness connector

Note:

- **Note the position of the transmission linkage in relation to the punch mark on the gear change mechanism.**

16. Remove the transmission linkage bolt. Retain the bolt for re-use.
17. Detach the transmission linkage from the gear change mechanism. Using the punch mark as a marker, realign the transmission linkage in an anti-clockwise direction by 9 splines.

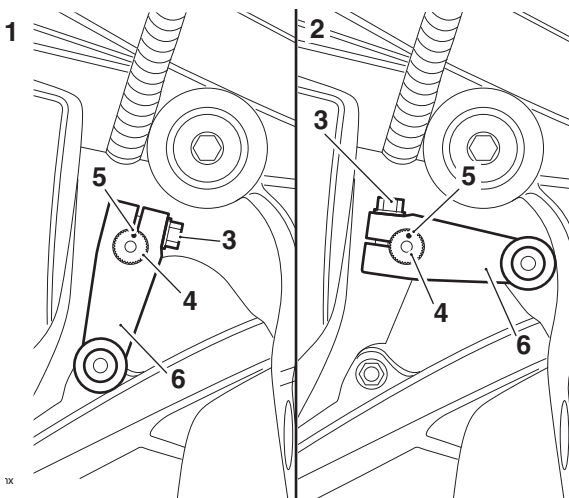

1. Original alignment
2. New alignment
3. Bolt
4. Gear change mechanism
5. Punch mark
6. Transmission linkage

18. Refit the transmission linkage bolt and tighten to **9 Nm**.

Note:

- **Note the routing of the fuel tank breather hoses and the wiring harness in front of the sprocket cover for installation.**

19. Remove the three screws and the sprocket cover. Retain the screws for re-use.
20. Retain the sprocket cover if the motorcycle is to be returned to its original condition.
21. Position the fuel tank breather hoses and wiring harness as noted for removal. Fit the sprocket cover from the kit and tighten the original screws to **9 Nm**.

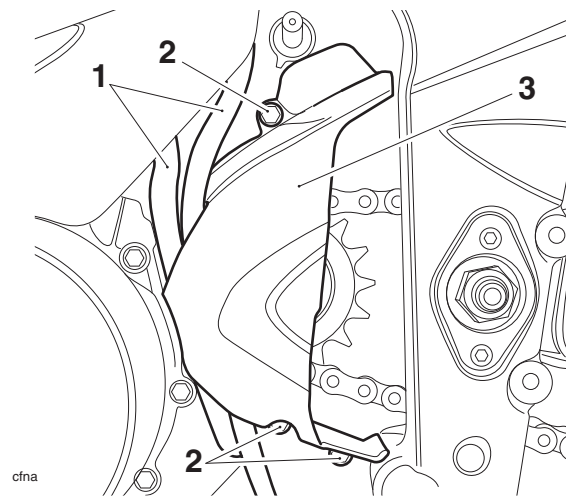

1. Fuel tank breather hoses
2. Screws
3. Sprocket cover

Note:

- **Note the position of the two spacers installed to the lower gearbox bolt, one on either side of the engine.**

22. Remove and discard the nut securing the rear lower gearbox bolt and remove the bolt. Collect the two spacers from the lower bolt.

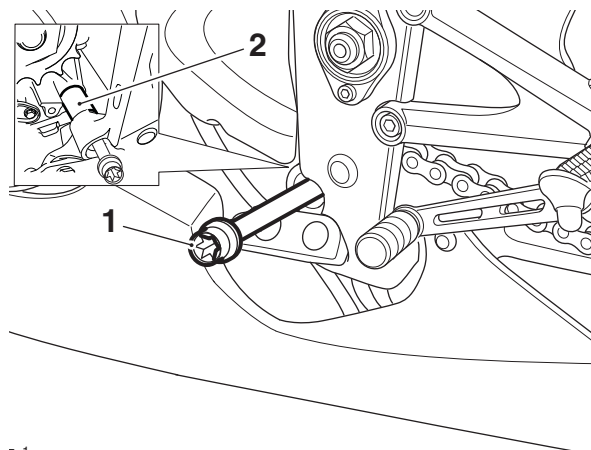

z_1

- 1. Rear gearbox bolt
- 2. Left hand spacer

23. Refit the rear lower gearbox bolt on the right hand side of the motorcycle, ensuring the two spacers are installed as noted for removal. Apply Loctite 243 to the thread of the mounting spacer. Fit and tighten the mounting spacer to **48 Nm**.

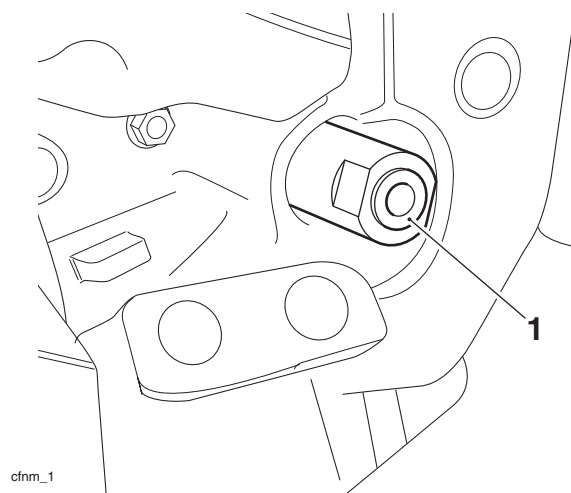

cfnm_1

- 1. Mounting spacer

24. Screw the M8 nut, right hand thread, fully on to the gear change lever assembly.

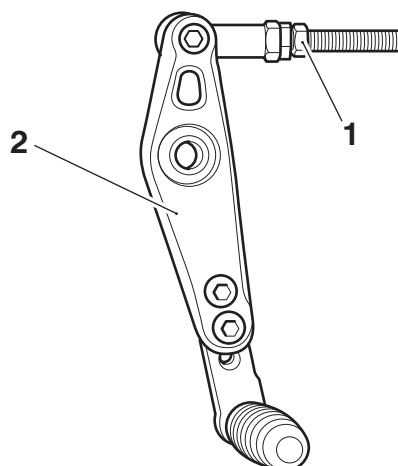

cfnb

- 1. Locknut
- 2. Gear change lever assembly

25. The new gear selector rod has a right hand thread at the smaller (10 mm outside diameter) end, and a left hand thread at the larger (12 mm outside diameter) end (adjacent to the spanner flats), as shown below.

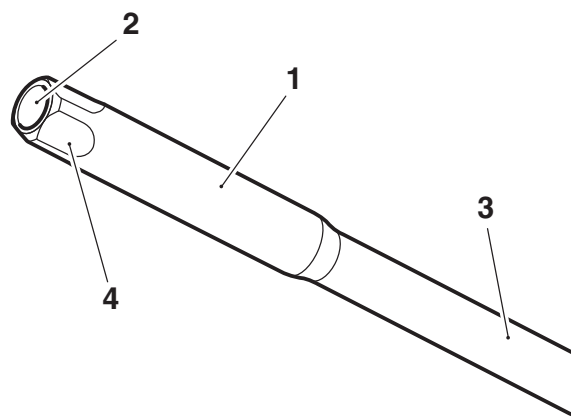

- 1. Gear selector rod
- 2. Left hand threaded end
- 3. Right hand thread end
- 4. Spanner flats

26. Screw the right hand threaded end of the new gear selector rod on to the gear change lever assembly up to the locknut.

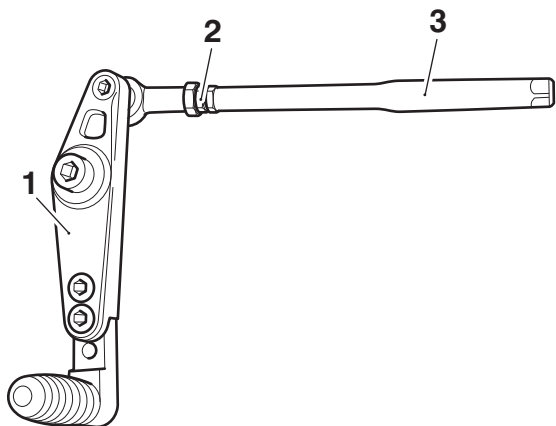

fnl_1

- 1. Gear change lever assembly
- 2. Locknut
- 3. Gear selector rod

27. Fit the M6 to M8 adapter and ball joint assembly fully on to the gear selector rod.

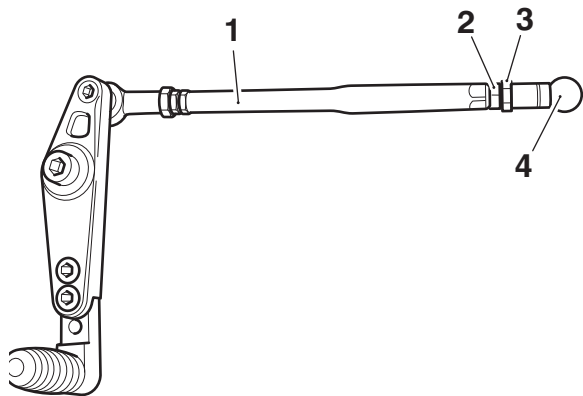

fnl

- 1. Gear selector rod
- 2. Locknut
- 3. M6 to M8 adapter
- 4. Ball joint

28. Attach the ball joint to the transmission linkage.

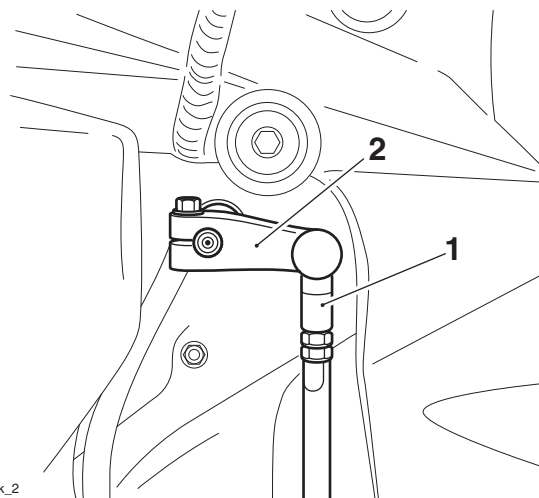

fnk_2

- 1. Ball joint
- 2. Transmission linkage

29. Refit the wire clip to retain the ball joint. Ensure the wire clip locates correctly in the ball joint before rotating the clip to lock in position.

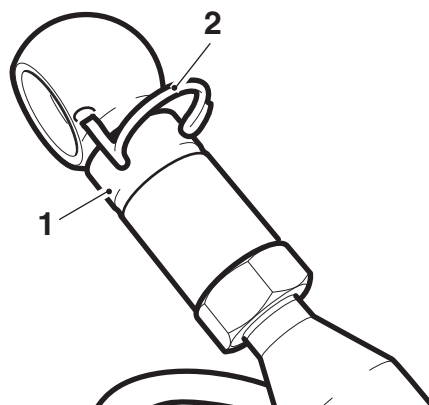

- 1. Ball joint
- 2. Wire clip

30. Attach the gear change lever assembly and bearing cap to the mounting spacer as shown below. Apply Locktite 243 to the thread of the screw. Fit and tighten the screw to **20 Nm**.

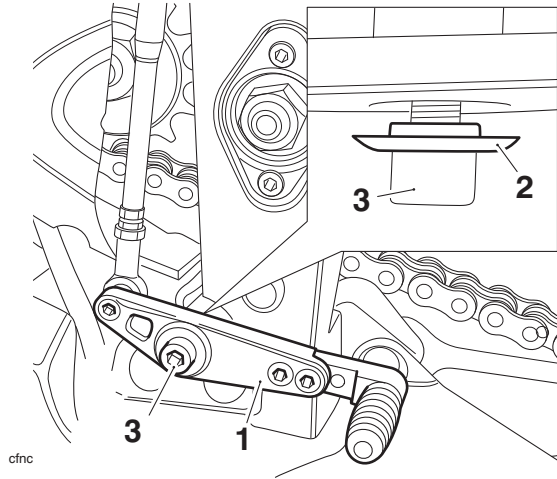

- 1. Gear change lever assembly**
2. Bearing cap
3. Screw

31. Fit the new footrest mounting assembly and tighten the original screws to **27 Nm**.

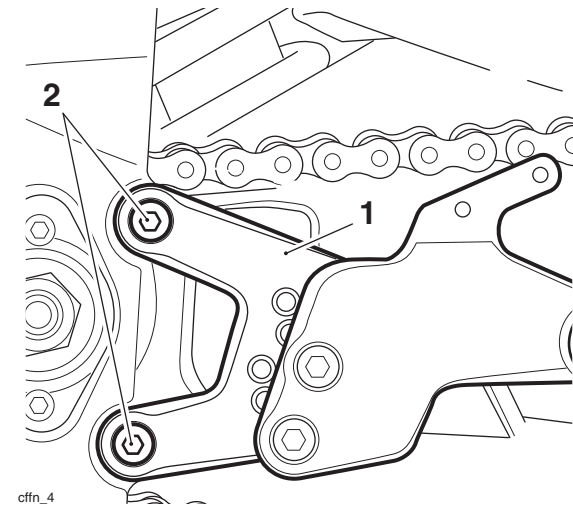

- 1. Footrest and mounting assembly**
2. Original screws

32. The footrest position can be adjusted to the rider's preferred position. To adjust the footrest position, remove the two screws and the footrest plate.

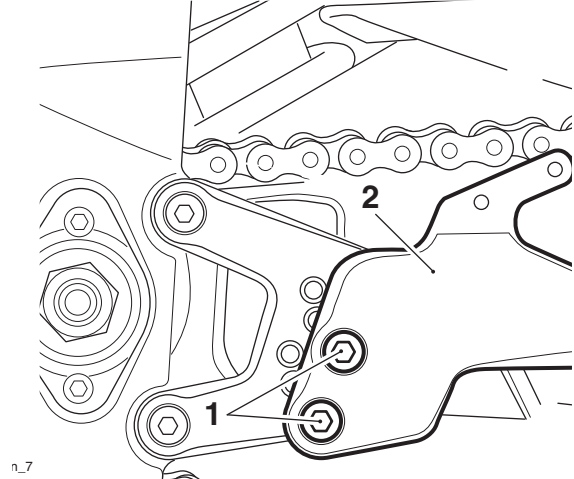

- 1. Screws**
2. Footrest plate

33. The illustration below shows the nine possible positions for the lower screw securing the footrest plate. The remaining holes are for the upper screw.

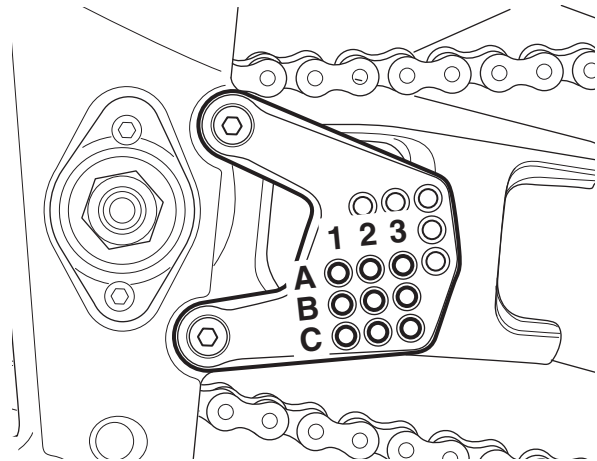

Possible Positions for the Lower Screw

Note:

- To ensure the right hand footrest plate is positioned at the same height as the left hand footrest plate, make a note of which hole is used for the lower screw, for example C1.

34. Refit the footrest plate and secure with the two screws, ensuring the lower screw is in one of the nine holes shown previously.

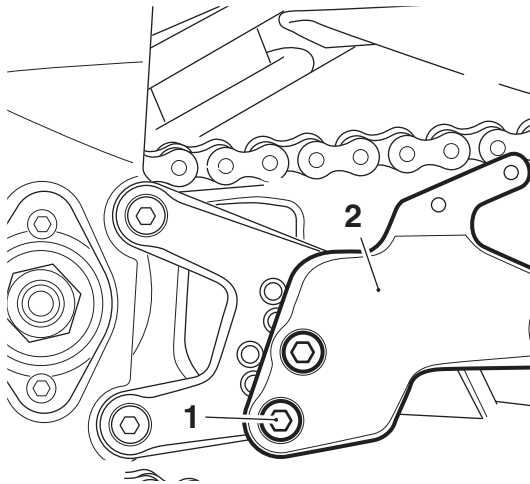

ffn_6

- 1. Lower screw**
2. Footrest plate

35. Check to see if the footrest is in the preferred position for the rider.
 36. Repeat steps 31 to 34 until the footrest is at the preferred position for the rider. Tighten the screws to **27 Nm**.
 37. Tighten the upper adapter to **9 Nm**.
 38. To adjust the gear change lever angle, turn the gear selector rod until the desired angle is achieved.

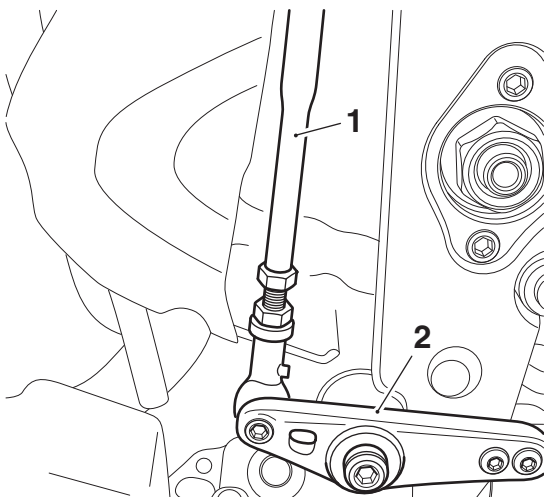

ne

- 1. Gear change rod**
2. Gear change lever assembly

39. Tighten the lock nuts on both ends of the gear selector rod to **6 Nm**.

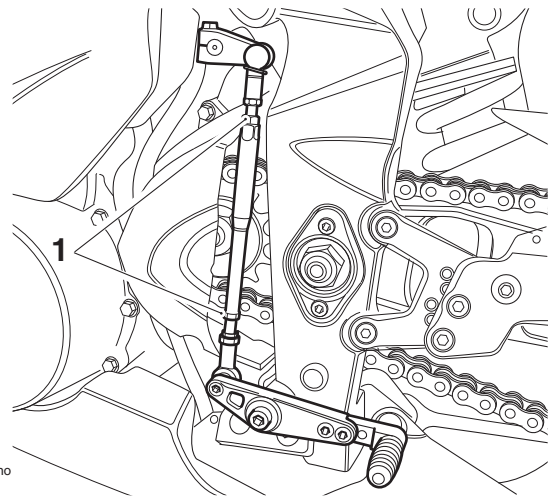

cfno

- 1. Lock nuts**

40. Recheck the torque of both adapters after the adjustment of the gear selector rod is completed.
 41. The length of the gear change lever can be adjusted to the rider's preferred position. To adjust the gear change lever, remove the two screws and slide the gear change peg in or out and secure with the two screws.

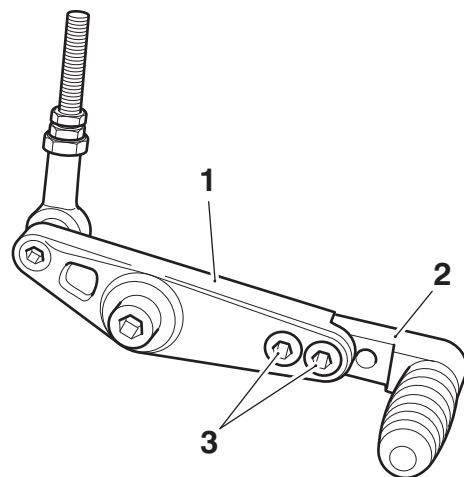

cfnd

- 1. Gear change lever assembly**
2. Gear change peg
3. Screws

Warning

Both screws must be used to secure the gear change peg to the gear change lever. The use of only one screw may result in the gear change peg becoming loose or falling off, resulting in loss of motorcycle control and an accident.

42. Repeat step 41 until the gear change lever is at the preferred position for the rider. Remove the screws, apply Locktite 243 to the screw threads and tighten to **9 Nm**.
43. Fit the supplied left hand heel guard to the footrest plate with the screws from the kit. Apply Locktite 243 to the screw threads and tighten to **6 Nm**.

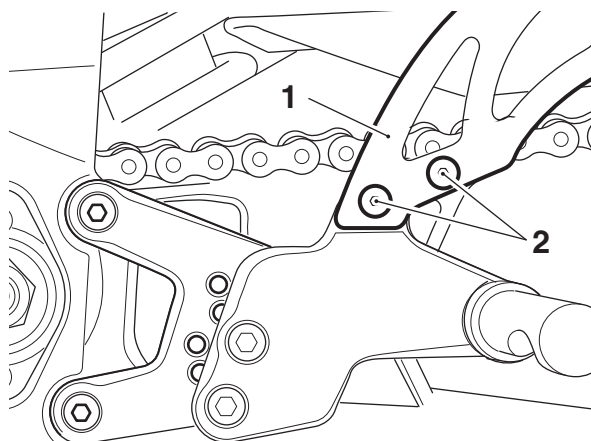

iu_3

- 1. Left hand heel guard**
2. Screws

Note:

- **Should the rider require the footrest position to be changed, repeat steps 32 to 42.**

Right Hand Footrest and Mounting Assembly

Note:

- **The new right hand footrest and mounting assembly is not equipped with a bracket for the rear brake light switch.**

44. Follow the route of the rear brake light switch harness to its connection with the main harness.

45. Disconnect the rear brake light switch from the main harness.

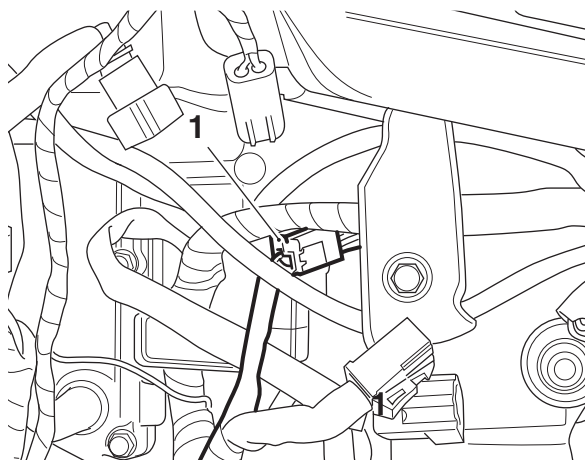

- 1. Rear brake light main harness connector**

46. Loosen the locknut on the rear master cylinder push rod.

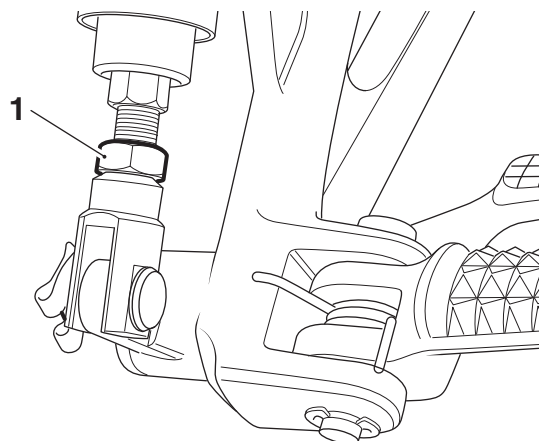

r1

- 1. Locknut**

47. Remove the clip from the brake pedal clevis pin.
Remove the clevis pin.

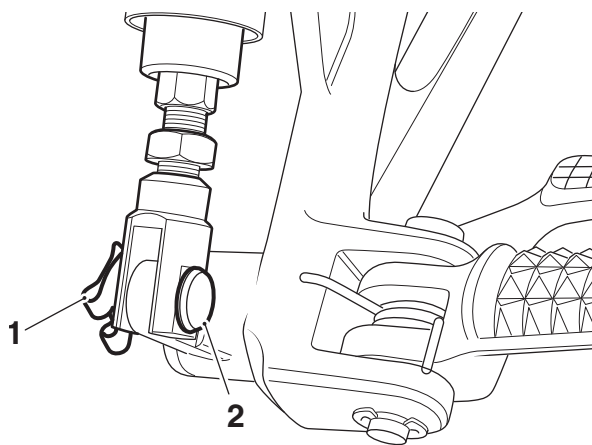

- 1. Clip**
2. Clevis pin

48. Remove the screws securing the rear brake master cylinder and heel guard to the footrest mounting. Retain the screws for re-use.

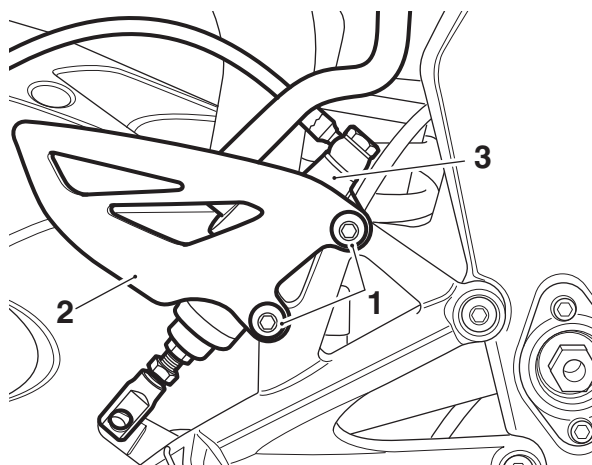

- 1. Screws**
2. Heel guard
3. Rear brake master cylinder

49. Remove the clevis and position the master cylinder aside.

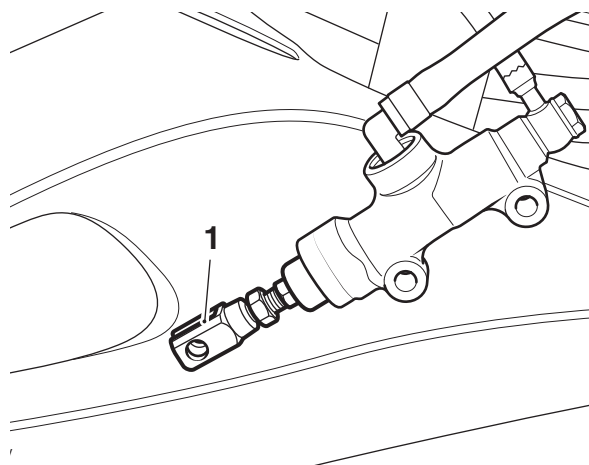

- 1. Clevis**

50. Remove the two screws and the right hand footrest mounting. Guide the rear brake light harness through the frame.

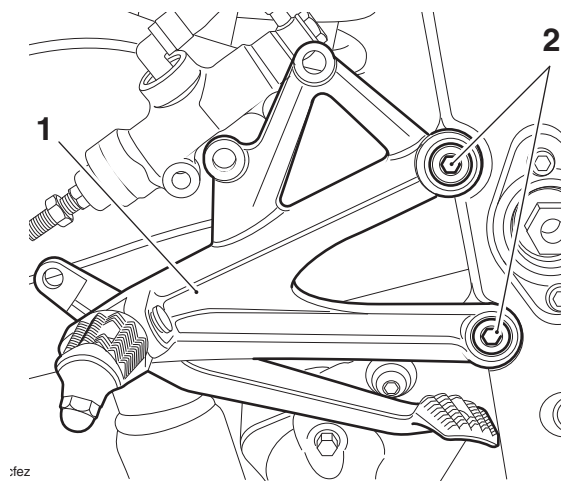

- 1. Footrest mounting**
2. Screws

51. Retain the screws for re-use.
52. Retain the following if the motorcycle is to be returned to its original condition:

- Clevis;
- Clevis pin;
- Clevis pin clip;
- Footrest mounting;
- Heel guard;
- Rear brake light switch;
- Rear brake light switch spring.

53. Attach the new ball joint on the brake pedal to the push rod.

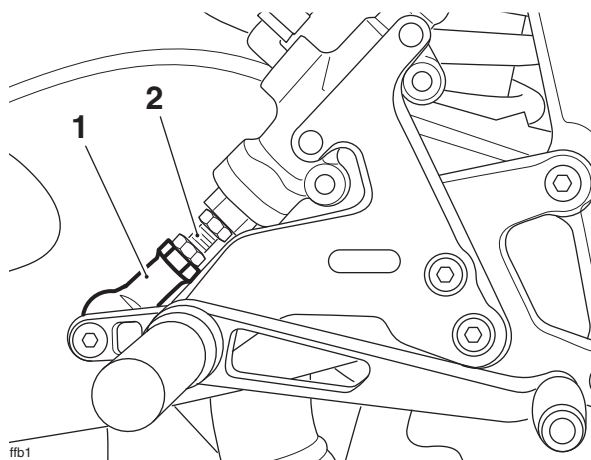

- 1. Brake pedal ball joint
- 2. Push rod

54. Attach the new right hand footrest assembly to the frame and tighten the original screws to **27 Nm**.

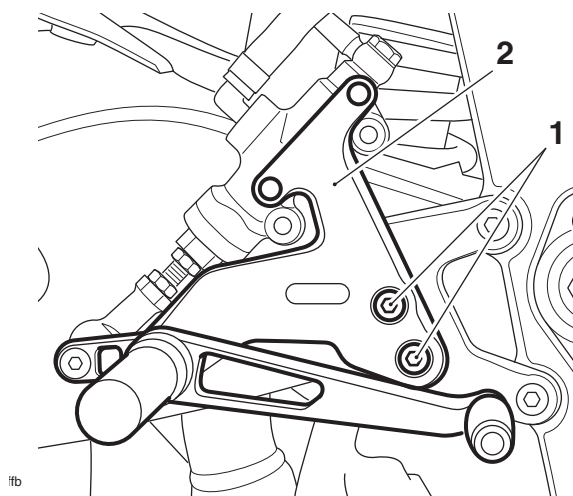

- 1. Screws
- 2. Right hand footrest assembly

! Caution

Both left hand and right hand footrest plates must be adjusted to the same position.

55. To adjust the footrest position, remove the two screws and the footrest plate.

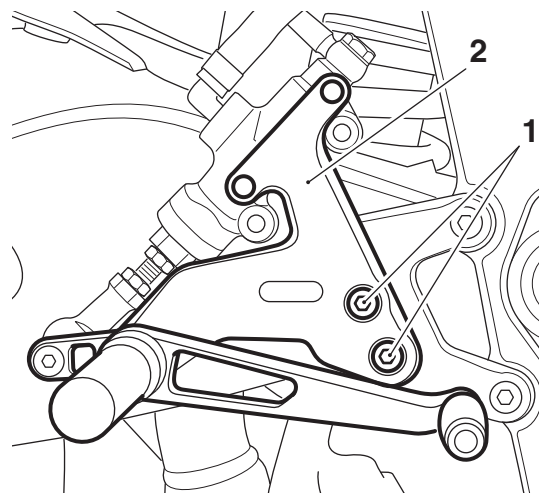

- 1. Screws
- 2. Footrest plate

56. The illustration below shows the nine possible positions for the footrest plate lower screw. The remaining holes are for the footrest plate upper screw.

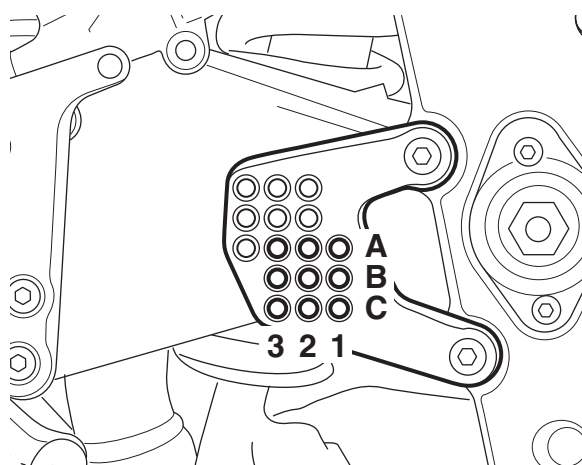

Possible Positions for the Footrest Plate Lower Screw

57. Refit the footrest plate and secure with the two screws, ensuring the lower screw is in the same hole location as the left hand footrest plate, for example C1. Tighten the screws to **27 Nm**.

58. Fit the brake master cylinder and supplied heel guard to the footrest plate with the existing M8 screws. Tighten the screws to **18 Nm**.

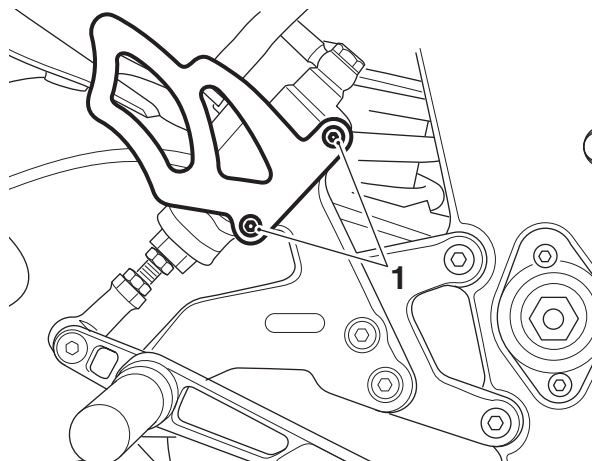

1. Screws

Note:

- **When the top edge of the brake pedal is 19.5 mm below the radius curve of the footrest plate, the pedal is at the standard factory setting.**

59. Using the measurement of 19.5 mm as a guide, turn the push rod top nut until the desired angle of the brake pedal is achieved.
60. Tighten the locknut against the ball joint to **17 Nm**.

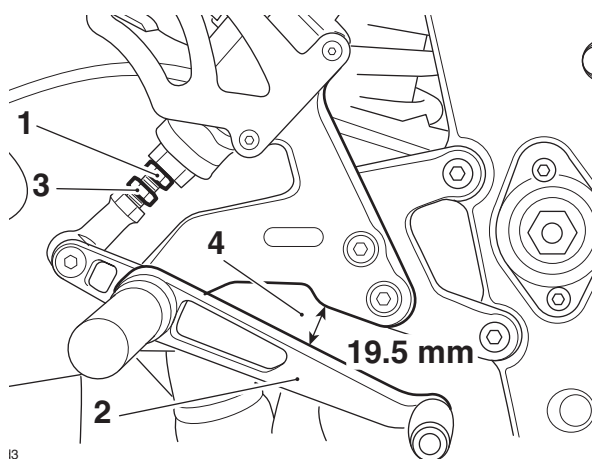

- 1. Push rod top nut**
2. Brake pedal
3. Locknut
4. Distance to be measured

! Caution

With the footrest plate lower screw in any of the nine positions, the brake fluid reservoir to master cylinder hose could be touching other components causing damage to the hose.

61. Check that the rear brake reservoir hose is not twisted or is touching any other components.

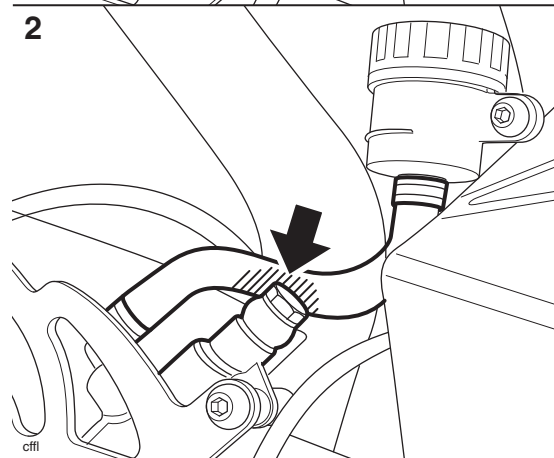
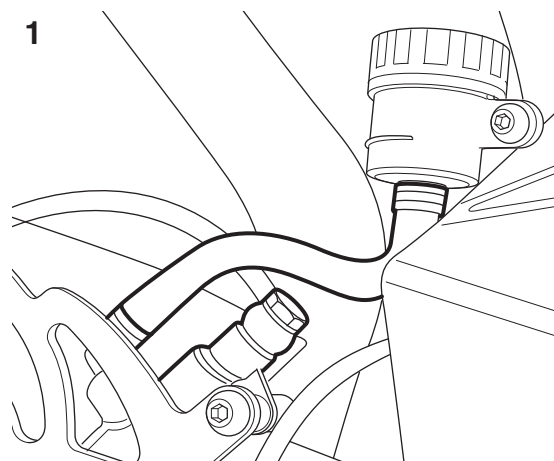

- 1. Correct routing**
2. Incorrect routing

! Caution

To prevent paint damage, do not spill brake fluid onto any area of the bodywork. Spilled brake fluid will damage paintwork.

62. Check the brake reservoir hose to exhaust intermediate pipe clearance. The clearance must be a minimum of 20 mm. If the clearance is less than 20 mm, fit the supplied support bracket between the frame and the rear brake fluid reservoir as follows:

63. Detach the brake fluid reservoir from the frame. Taking care not to invert the brake fluid reservoir, lay it to one side.

Note:

- **Discard the screw after removal. If the motorcycle is to be returned to its original condition, install a new screw.**

64. Fit the support bracket provided to the frame with the M6 washer and screw provided. Ensure the bracket is fitted as shown in the lower illustration below. Do not tighten the screw at this stage.

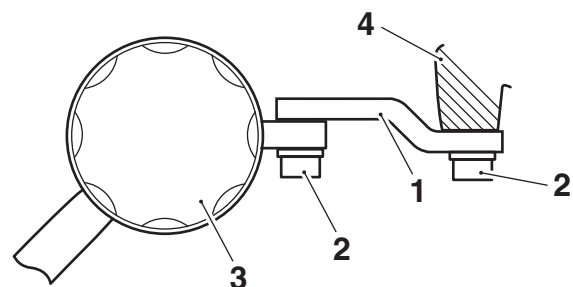
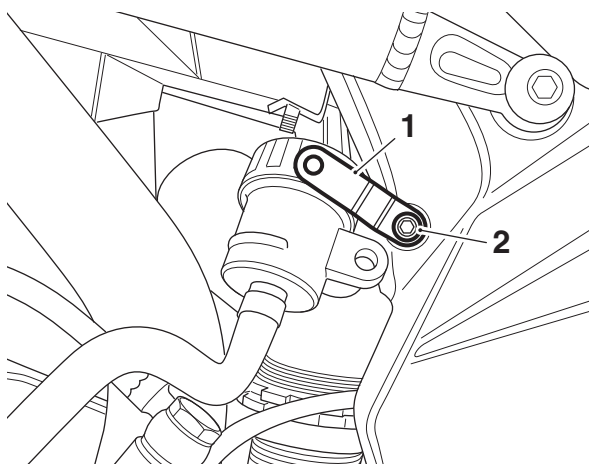

- 1. Support bracket
- 2. Screw
- 3. Rear brake fluid reservoir
- 4. Frame lug

65. Attach the rear brake fluid reservoir to the support bracket with the M6 washer and screw provided. Do not tighten the screw at this stage.

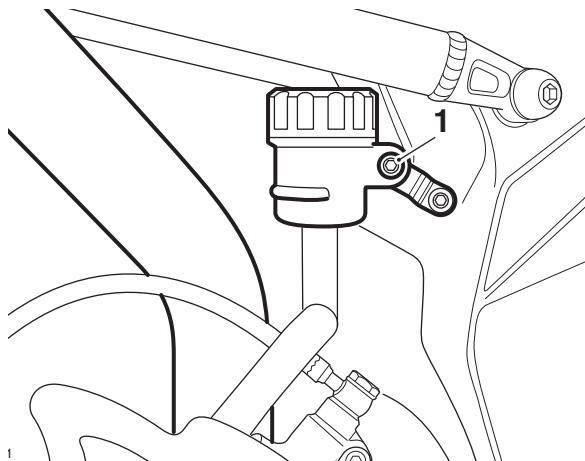

1. Screw

! Warning

The rear brake fluid reservoir and hose must be at least 20 mm from the exhaust pipe. The heat from the exhaust pipe may cause damage to the reservoir and hose resulting in loss of brake fluid, loss of motorcycle control and an accident.

66. Position the rear brake fluid reservoir so that the reservoir hose is clear from obstruction and the reservoir has a minimum distance of 20 mm from the exhaust pipe. Tighten the two screws to **7 Nm**.

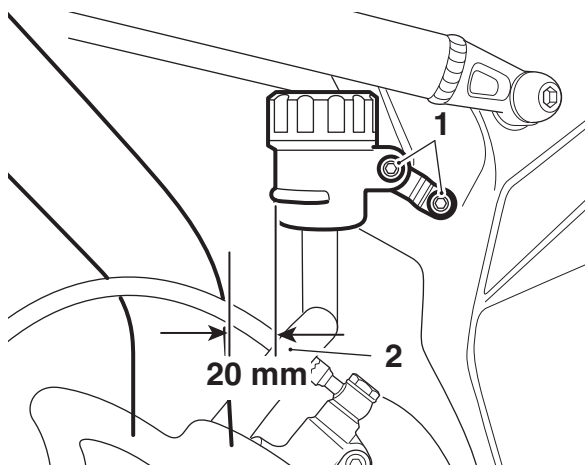

- 1. Screws
- 2. Minimum distance from the exhaust pipe

Note:

- **Should the rider require the footrest position to be changed, remove the heel guard and repeat steps 55 to 62.**

67. Refit the fuel tank as described in the service manual.
68. Reconnect the battery, positive (red) lead first.
69. Refit the rider's seat as described in the service manual.

Warning

It is dangerous to operate the motorcycle with defective brakes; you must have your authorised Triumph dealer take remedial action before you attempt to ride the motorcycle again. Failure to take remedial action may reduce braking efficiency leading to loss of motorcycle control and an accident.

70. Check for correct brake operation. Rectify as necessary.

Replacing Components

Refer to the following illustrations for torque figures and for which fixings require Loctite 243.

Warning

When replacing components on this accessory kit, some of the fixings are required to have Loctite 243 added to their threads. This is to ensure that these fixings remain secure at their specified tightening torque. Failure to use loctite 243 may result in component detachment leading to loss of motorcycle control and an accident.

Left Hand Footrest and Mounting Assembly

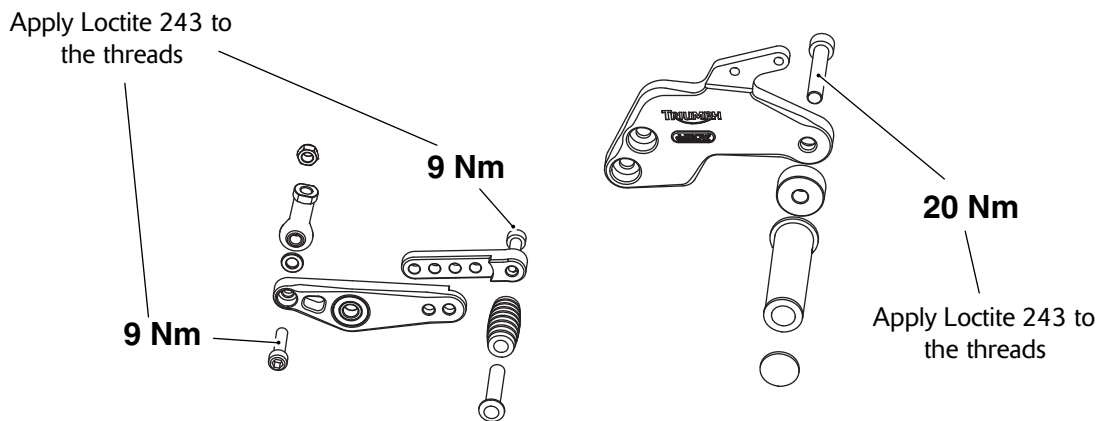

Right Hand Footrest and Mounting Assembly

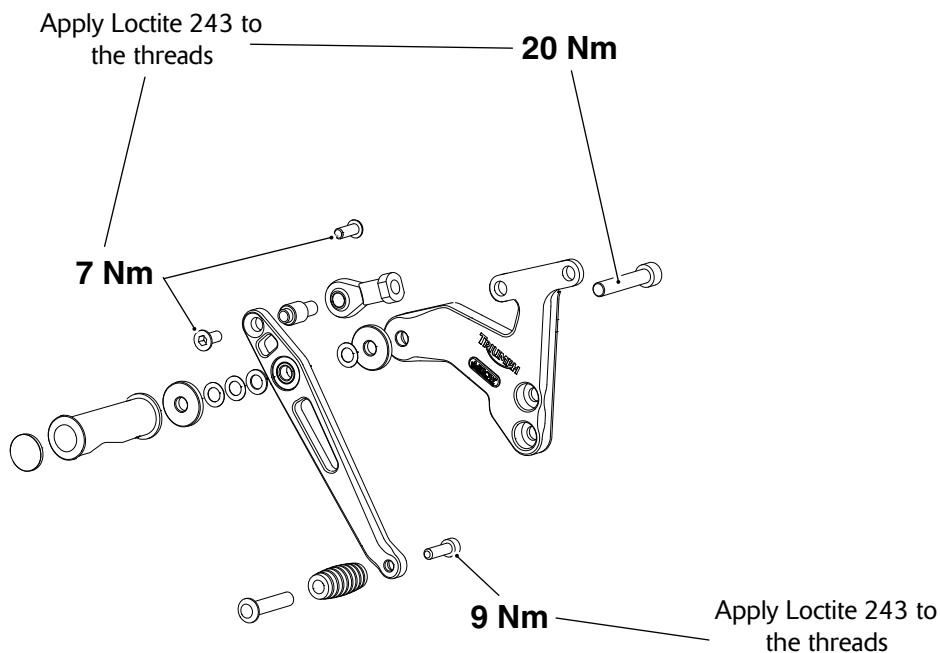

Warning

After fitting the accessory kit the gear change lever operation has been reversed. Operate the motorcycle in a safe area free from traffic to gain familiarity with the reversed operation of the gear change lever. Operation of the motorcycle when not familiar with the reversed gear change operation may result in loss of motorcycle control and an accident.

Warning

If, after fitment of this accessory kit, you have any doubt about the performance of any aspect of the motorcycle, contact an authorised Triumph dealer and do not ride the motorcycle until the authorised dealer has declared it fit for use. Riding a motorcycle when there is any doubt as to any aspect of the performance of the motorcycle may result in loss of control of the motorcycle leading to an accident.

Warning

After fitting the accessory kit the motorcycle will exhibit new handling characteristics. Operate the motorcycle in a safe area free from traffic to gain familiarity with any new characteristics. Operation of the motorcycle when not familiar with any new handling characteristics may result in loss of motorcycle control and an accident.

Rearsets, Race, Standard Shift (Arrow)

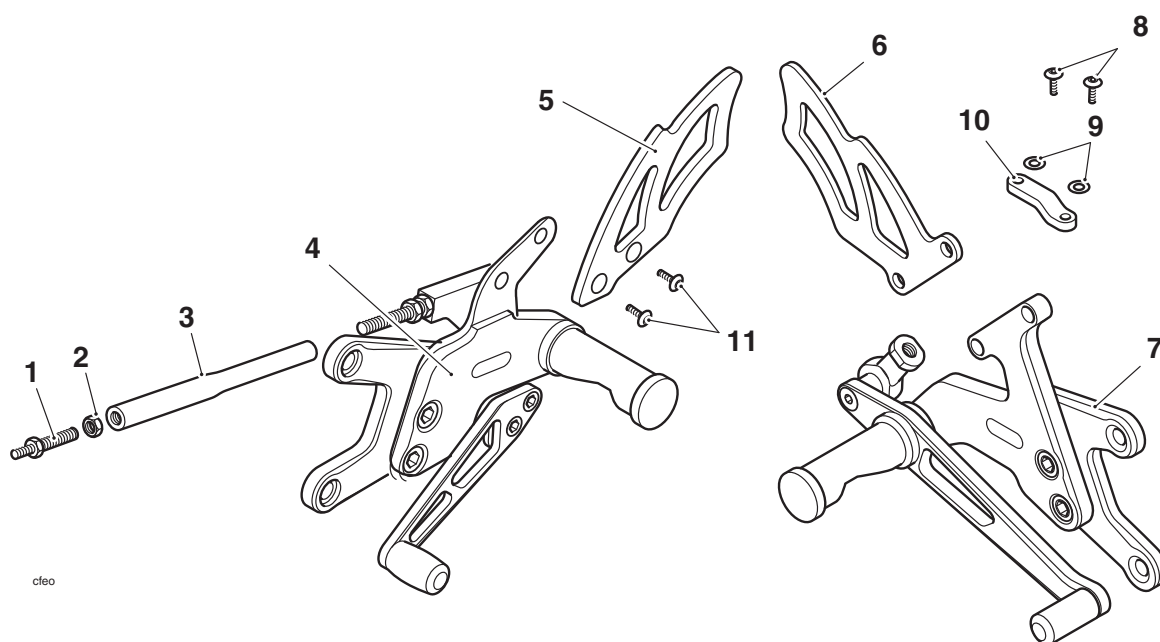

Parts Supplied - A9750539

Item	Description	Qty
1	Adaptor, M6 to M8 - left hand thread	1
2	Nut, M8 - left hand thread	1
3	Gear selector rod	1
4	Footrest mounting assembly - left hand side	1
5	Heel guard, left hand side	1
6	Heel guard, right hand side	1
7	Footrest mounting assembly, right hand side	1
8	Screw, M6	2
9	Washer, M6	2
10	Support, rear brake fluid reservoir	1
11	Screw, M5	2

Note:

- For fitment, refer to the comprehensive fitting instructions supplied with the rearset kit.

NO WARRANTIES ARE PROVIDED FOR THIS RACING KIT. TRIUMPH MOTORCYCLES DOES NOT PROVIDE ANY WARRANTIES FOR THIS RACING KIT OR FOR ANY OF THE PARTS IN THIS RACING KIT. ALL WARRANTIES, EXPRESS OR IMPLIED, ARE SPECIFICALLY DISCLAIMED. TRIUMPH MOTORCYCLES DOES NOT PROVIDE ANY WARRANTIES OF MERCHANTABILITY OR FITNESS FOR A PARTICULAR PURPOSE. IN NO EVENT SHALL TRIUMPH MOTORCYCLES, ITS RELATED COMPANIES OR UNITED STATES REPRESENTATIVES BE LIABLE FOR ANY ALLEGED BREACH OF WARRANTIES INCLUDING WARRANTIES OF MERCHANTABILITY OR WARRANTIES OF FITNESS FOR A PARTICULAR PURPOSE. TRIUMPH MOTORCYCLES LTD, ITS RELATED COMPANIES AND ITS REPRESENTATIVES IN THE UNITED STATES, SPECIFICALLY DISCLAIM ALL LIABILITY ARISING OUT OF THE USE OF THIS RACING KIT. IN NO EVENT SHALL TRIUMPH MOTORCYCLES LTD, ITS RELATED COMPANIES OR ITS UNITED STATES REPRESENTATIVES BE LIABLE FOR ANY DAMAGES ARISING OUT OF THE USE OF THIS RACING KIT. THIS MEANS THAT, IN NO EVENT, SHALL TRIUMPH MOTORCYCLES LTD, ITS RELATED COMPANIES OR ITS UNITED STATES REPRESENTATIVES BE LIABLE FOR ANY GENERAL, INDIRECT OR CONSEQUENTIAL DAMAGES ARISING OUT OF THE USE OF THIS RACING KIT.